

RS70



Hardware system for residential (garage) overhead doors

Built-in height 75mm, springs in rear

INSTALLATION / MAINTENANCE / USAGE

© All rights reserved. FlexiForce® 2009

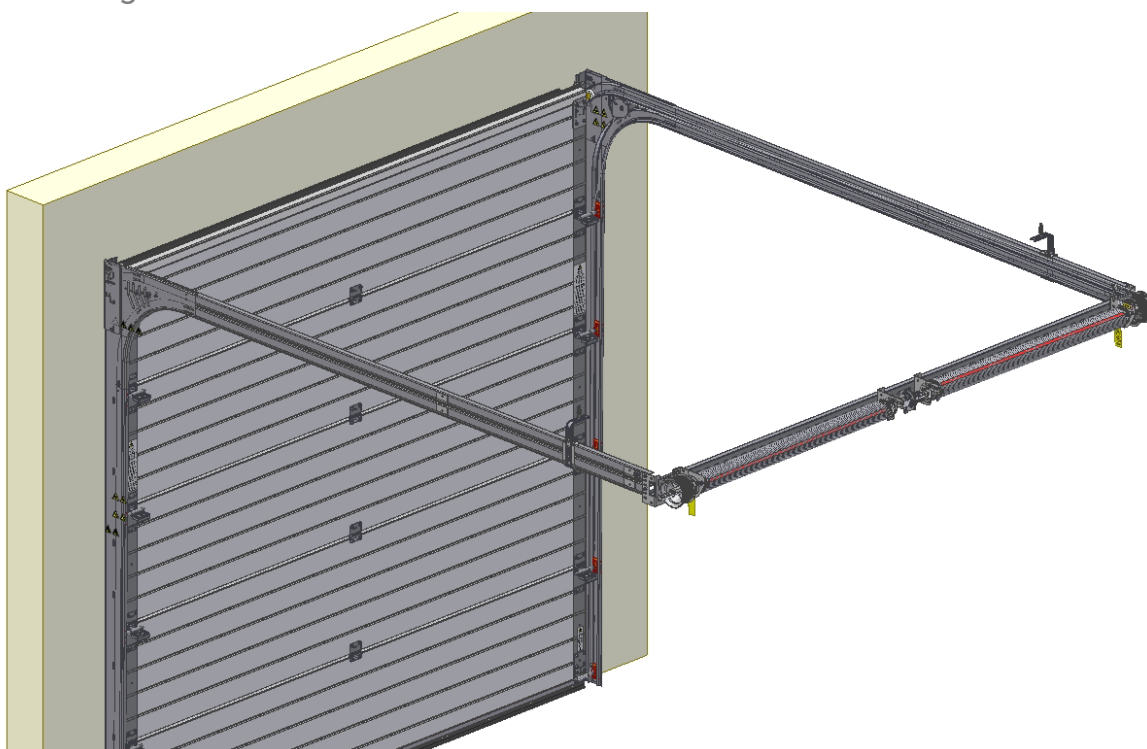

FF manual GB

rev.0 Feb-09



ATTENTION! GENERAL WARNING!

To install, use and maintain this door system safely, a number of precautions must be taken. For the safety of all concerned, pay heed to the warnings and instructions given below! If in doubt, contact your supplier.



SPECIAL SAFETY WARNINGS OR REMARKS IN THIS MANUAL ARE INDICATED WITH THIS SYMBOL. READ THESE WARNINGS CAREFULLY!

- ✓ This manual has been written for use by experienced fitters and as such is not suitable for d.i.y. purposes or for use by trainee fitters.
- ✓ This manual describes the installation of the hardware set components, door sections (panels) and refers to installation manuals of the electrical operator. Be sure to supplement this manual if needed with instructions for any additional components not described in this manual.
- ✓ Before starting, read this manual carefully!
- ✓ Certain components may be sharp or have jagged edges. As such you are advised to wear safety gloves.
- ✓ All the components which have been supplied are designed for use with this specific overhead door. Replacement or adding additional components may have an adverse effect on the safety of, and the guarantee on, the door. Also the CE-approval which has been granted to this door will be cancelled when components are changed or installation is not done according to this manual! Installer is responsible for this.
- ✓ Ensure that there is sufficient light during installation. Remove obstacles and dirt. Make sure that there is no one else present other than the fitters. Other people (children!) may get in the way or endanger themselves during the installation.

GUARANTEE, CONDITIONS AND TERMS

The general terms and conditions of delivery and payment issued by the Metaalunie and designated as METAALUNIE CONDITIONS are fully applicable to all our quotations, contracts and their implementation. We expressly reject all other terms and conditions. On request we will send you a copy of these terms and conditions free of charge. A copy may also be downloaded from our website www.flexiforce.com.

FlexiForce strives to deliver 100 % in conformance with the order. In practice, in spite of all our controls, this is not always possible. However we will rectify any errors as quickly as possible, in order to minimise the inconvenience caused to you or the user. As such, it is important that you inform us as soon as possible about any problem with the delivery (include the order number and week of production) and give us the opportunity to offer a suitable solution.

FlexiForce will only reimburse third party costs if we have given explicit permission for this in advance. The reimbursement is based on normal rates and travelling expenses over distances of 1 hour away at most.

For large-scale projects we strongly advise you to first install 1 door completely before installing the other doors. In this way, any errors can be detected early on and rectified comparatively cheaply.

This manual does not confer any rights. Technical modifications may be made without written notice.

FlexiForce has endeavoured to design and put together this hardware set in conformance with the applicable CE-norms. However, we recommend to check our configuration against any local national specification.

FF manual GB

rev.0 Feb-09



FlexiForce has applied the mandated INITIAL TYPE TESTING for doors described in this manual, at the SP-Institute in Sweden (as Notified Body Nr. 0402). The INITIAL TYPE TESTING REPORT that has been rewarded, can be transferred to the door producing company. This is needed to complete your CE files according to product standard EN13241-1. Contact FlexiForce for acquiring this report.

APPLICATION RANGE

FlexiForce has developed a new hardware system for garage overhead doors. The system includes the following features:

- Suitable for single and double garages, Wmax = 5.000 mm, Hmax = 3.000 mm.
- The horizontal track set is standard reinforced with side plate RX560L/R with pulley system
- Advised max door weight is 165 kg. Each spring break device is approved to 125kg.
- CE approved when selecting the proper FlexiForce components.

We wish you every success with the installation of this hardware set. If anything is unclear or should you have queries, you should of course contact Flexi-Force B.V. or your supplier.

This set has to be completed with the assembled door sections. Panels brands and types according to the list of approved panels.

NB! FlexiForce has introduced a new system for shaft installation, so called SUPERCLICK®. There is a separate manual available for this system (attachment). In this manual, the SuperClick® system is marked with this sign:



NB! FlexiForce recommends to apply our "light" hardware range for garage doors. In this manual only "light" components are selected.



Attention! In this set, the fixing material required to install the track set to the building is not included. It is the responsibility of the qualified door installer to make sure that the building (stone, concrete, wood, etc.) is strong enough at the points of fixation to ensure a reliable construction. The door installer has to select proper fixing materials.

RECOMMENDED ADDITIONAL MANUALS

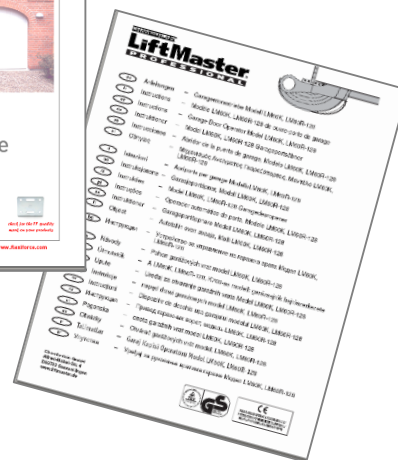

IN THIS MANUAL:

- Attention, general warnings	2
- Guarantee, terms and conditions	2
- Application range	3
- Recommended additional manuals	3
- Tools for correct and rapid assembly	5
- Applied fixation materials	5
- RS70 System overview	6
- Installing vertical track system	7
- Installing horizontal track system	8
- Shaft system installation	11
- Panel <> Hardware installation	14
- Cables & Torsion springs	17
- Finishing the door	19
- Optional: E-operation	23
- Panel assembly	24
- Troubleshooting	27
- Dismantling the overhead door	28
- Maintenance and replacement of parts	29

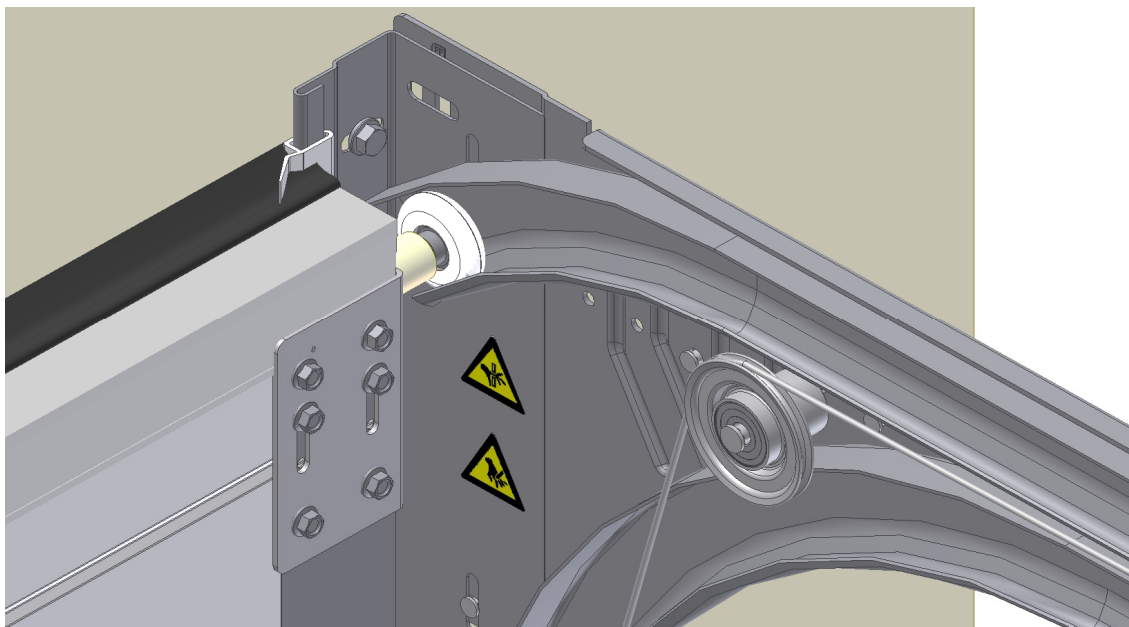

TOOLS FOR CORRECT AND RAPID ASSEMBLY

(Battery) drill with	Bit 4,0 mm
	Bit 4,5 mm
	Bit 6,5 mm
	Plug 10 mm
	Plug 13 mm
Hexagonal key	4 mm
Socket screw spanner	8mm (in)
Ring /open ended spanner	10 mm
Ring /open ended spanner	13 mm
Ring /open ended spanner	15 mm
Ring /open ended spanner	17 mm
Socket wrench	with ¼" square
Wrench	
Gluing clamp	
Cord	
Water level (hose)	
2 blocks of ca. 20 en 40mm in height	
Measuring equipment	

APPLIED FIXATION MATERIALS

The applicable fixation material is described in the drawings of this manuals. Below an overview of the applied fasteners and optional alternatives.

1055BV, self-tapping screw
Max torque 10Nm, key 10

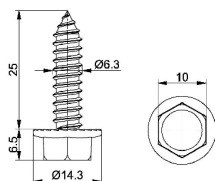

Alternatives: 1055D, screw, 6,3x25mm, with drill-point
1053BV, screw 6,3x35mm
1053D, screw 6,3x35mm, with drill-point
1054-25, 1054-35, screw with socket hex cap, drill point
1054W-25, 1054W-35, screw with socket hex cap (RAL9010)
Optional: 1055CAP10, white (RAL9010) cover for screws (key 10)

1070B35, bolt M8x25
1068M, nut M8

Max. torque 13Nm, key 13

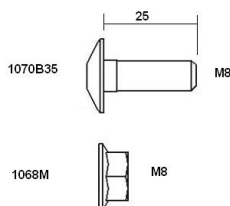

1006B, press bolt
1062M, nut M6

Max. torque 9,1Nm, key 10

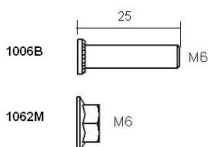

1062B, bolt M6x16
1062M, nut M6

Max. torque 5,3Nm, key 10

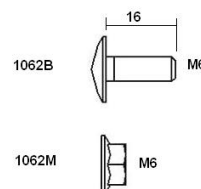

1071BC, bolt M8x12, SuperClick® secure bolt
Max. torque 10Nm, key 13

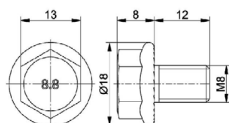

NB! Fixation material for installing to wall and ceiling is not included in this manual!

FF manual GB

rev.0 Feb-09

RS70 SYSTEM OVERVIEW

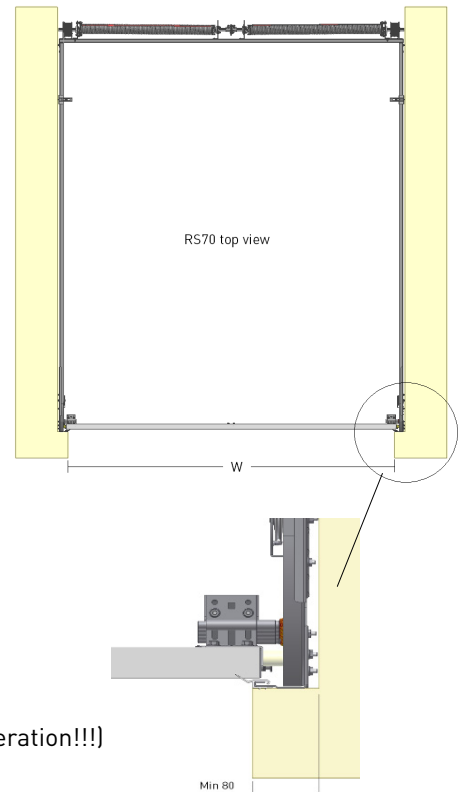
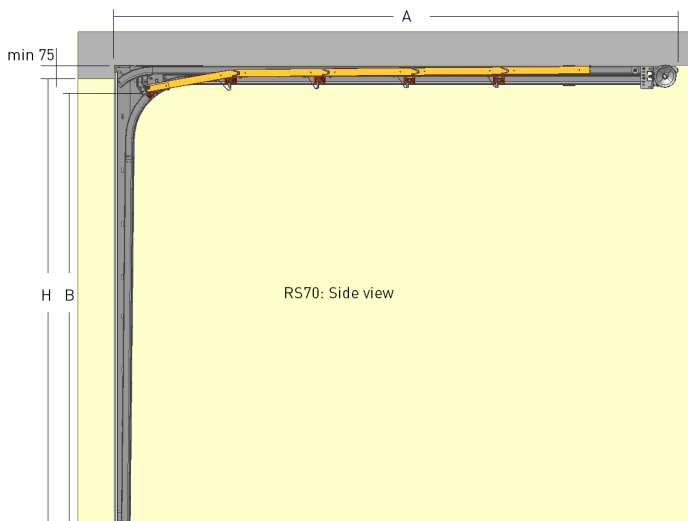
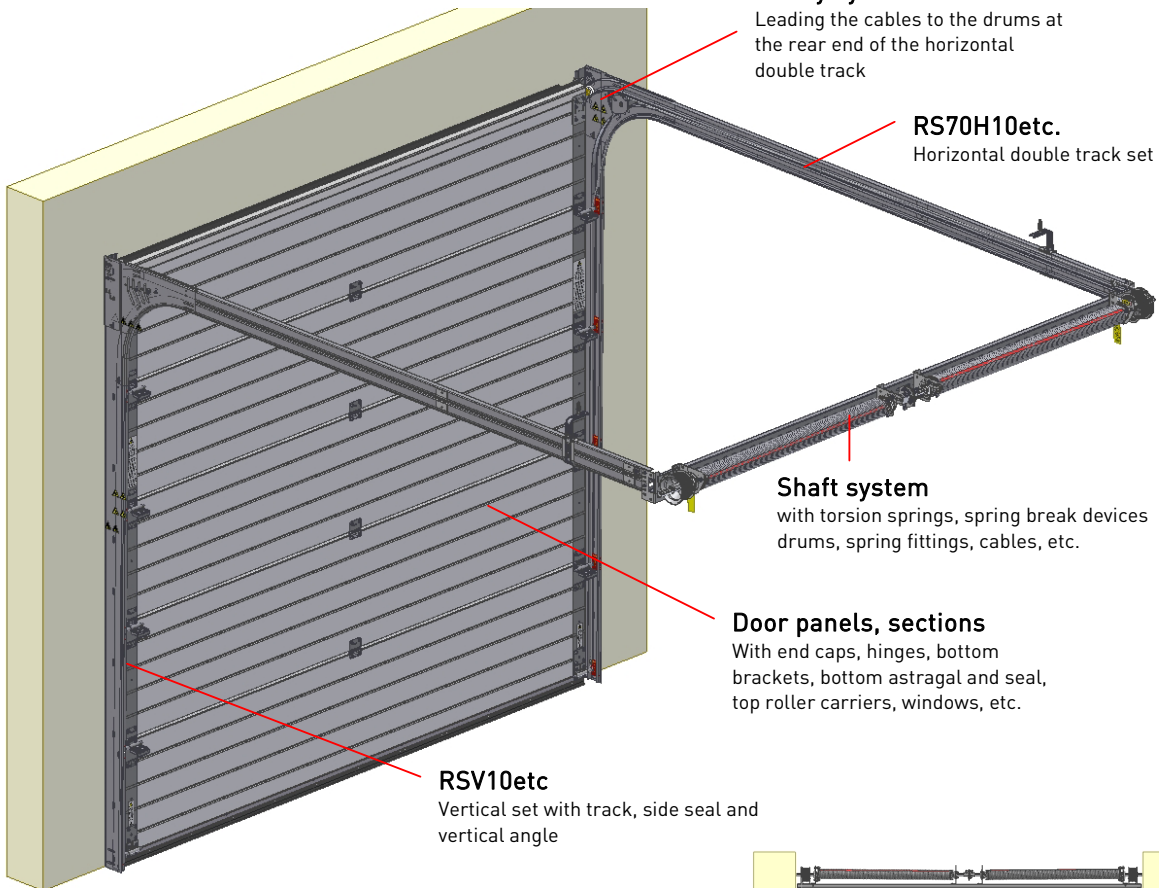

$B = H - 70\text{mm}$ for manual operated doors
 $B = H - 0\text{mm}$ for e-operated doors (NB! See Chapter E-operation!!!)

FF manual GB

rev.0 Feb-09

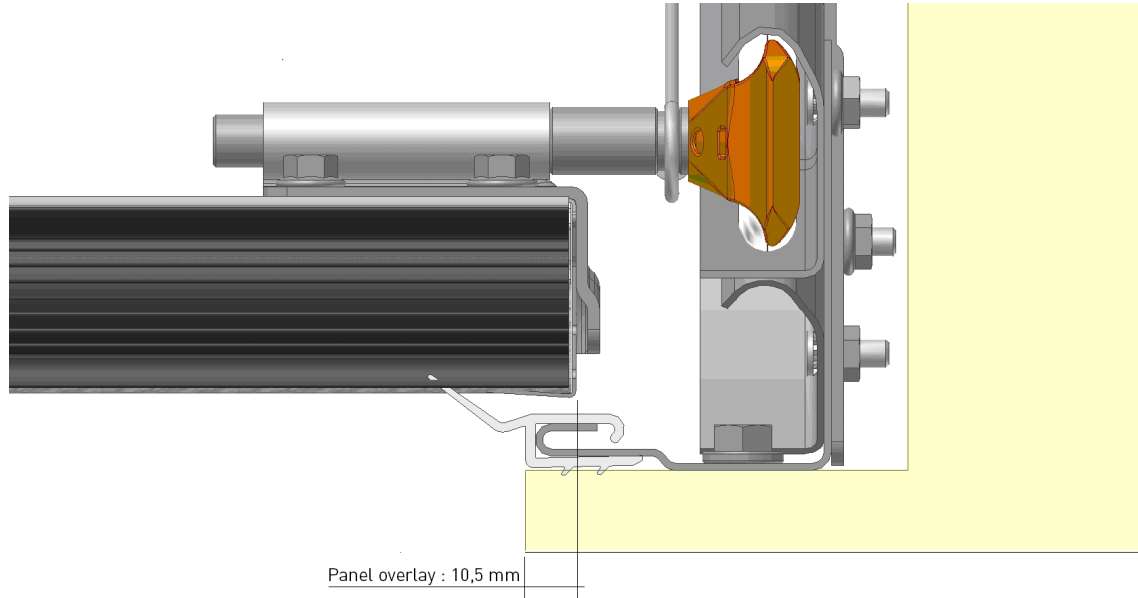

INSTALLING VERTICAL TRACK SYSTEM

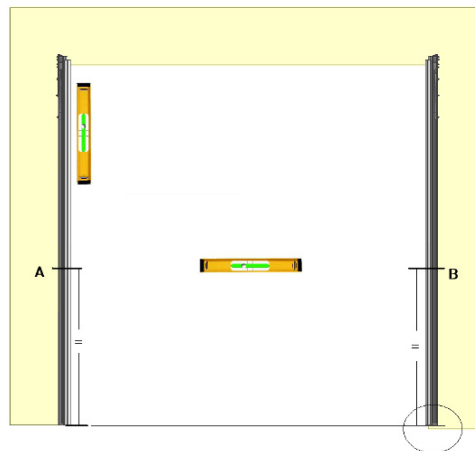
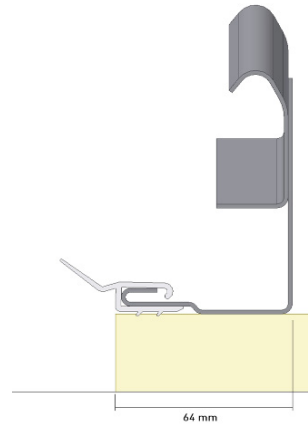
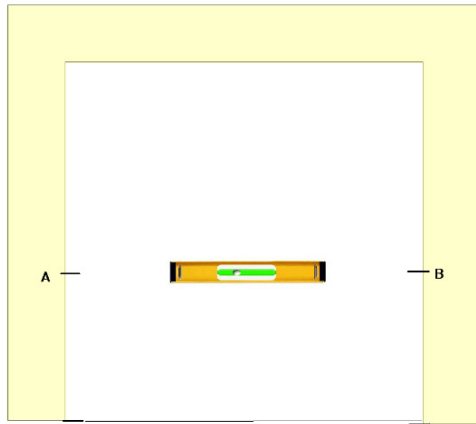

FF manual GB

rev.0 Feb-09

VERTICAL TRACK SET

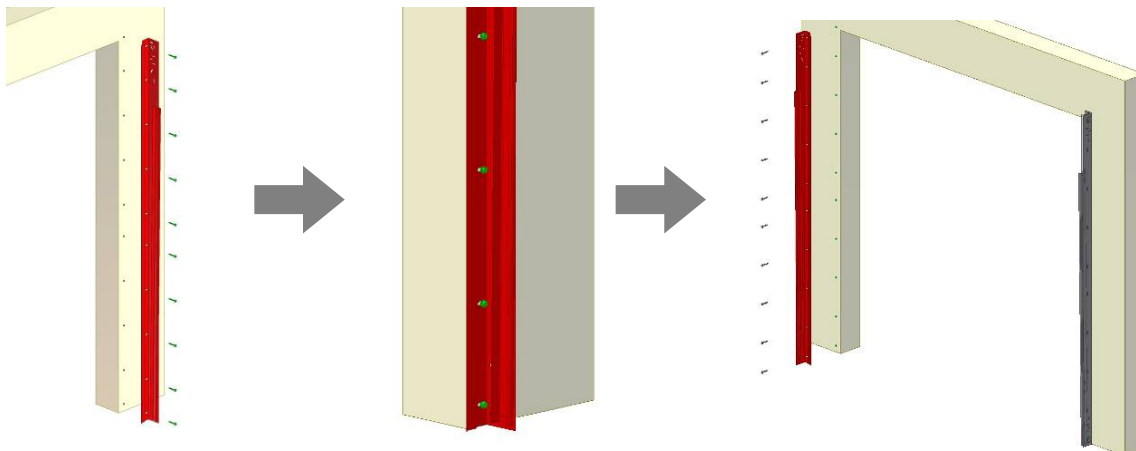

HORIZONTAL TRACK SET

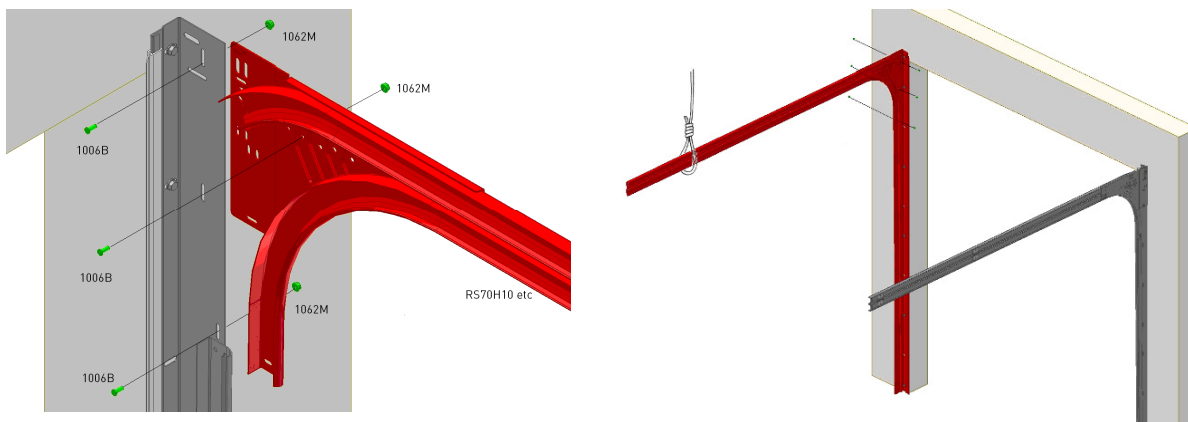

PULLEY SYSTEM INSTALLATION

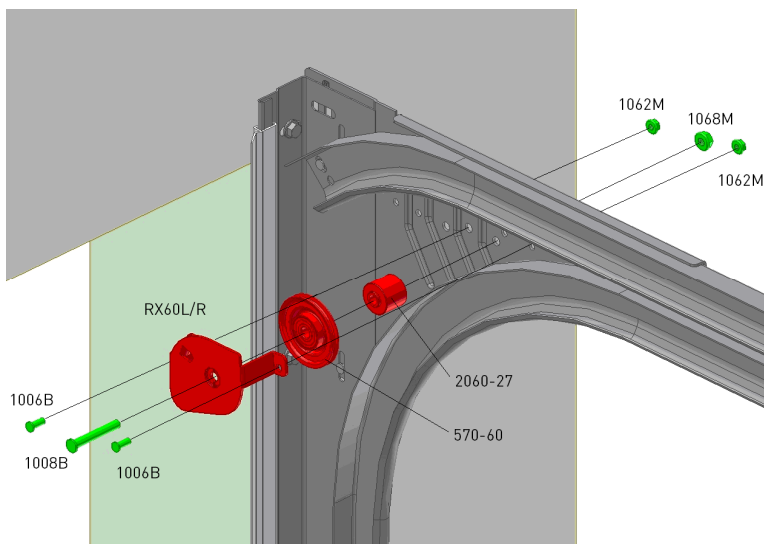

NB! Optional installation of RX80L/R and 570-80 pulley.

FF manual GB

rev.0 Feb-09

CONNECTION HORIZONTAL TRACKS

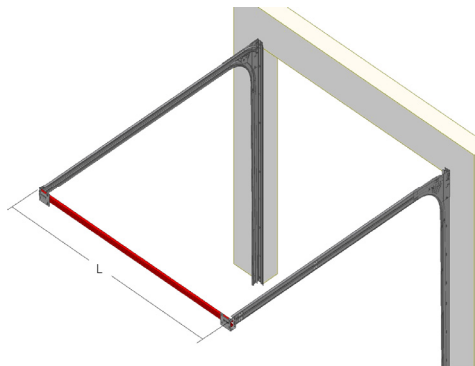
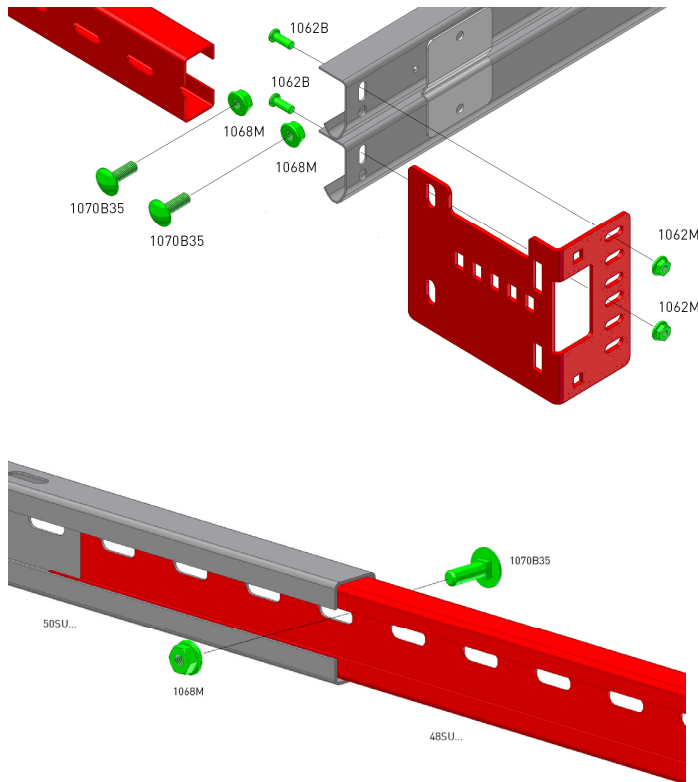

L = days opening width + 134mm

SUSPENSION HORIZONTAL TRACK TO CEILING

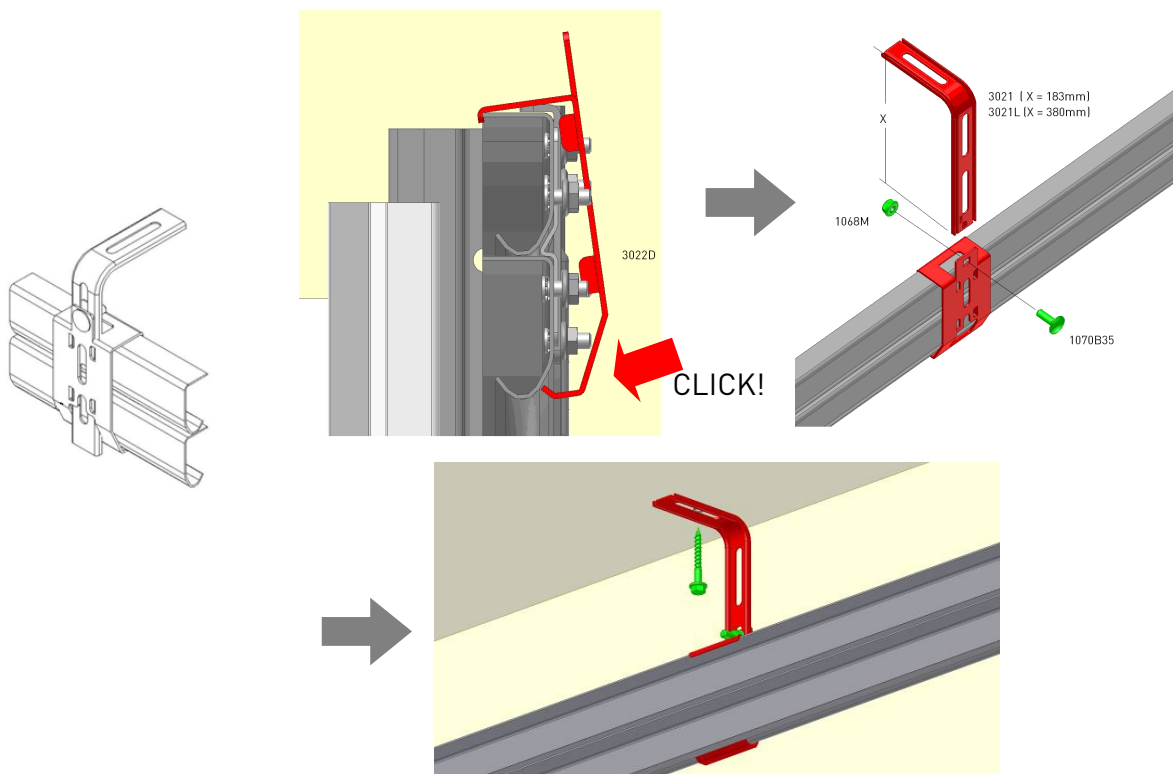

FF manual GB

rev.0 Feb-09

SHAFT SYSTEM INSTALLATION

DOOR W<3000mm

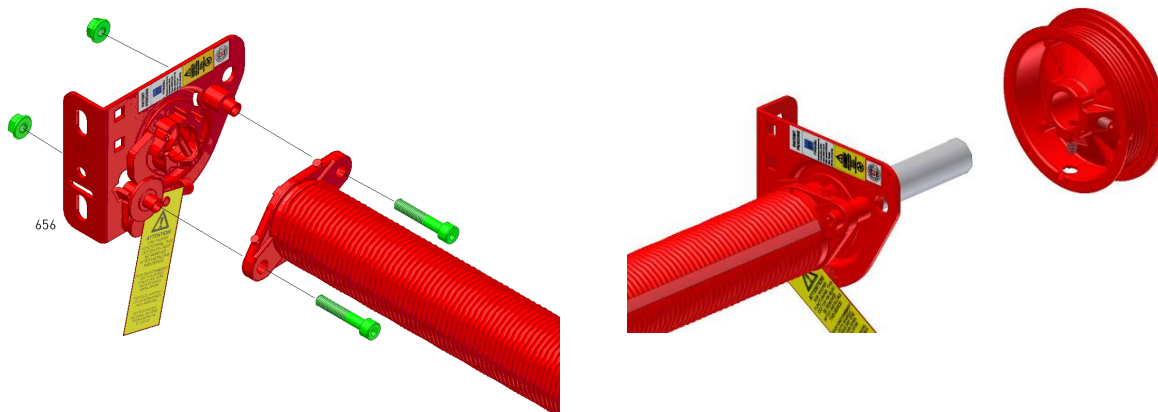
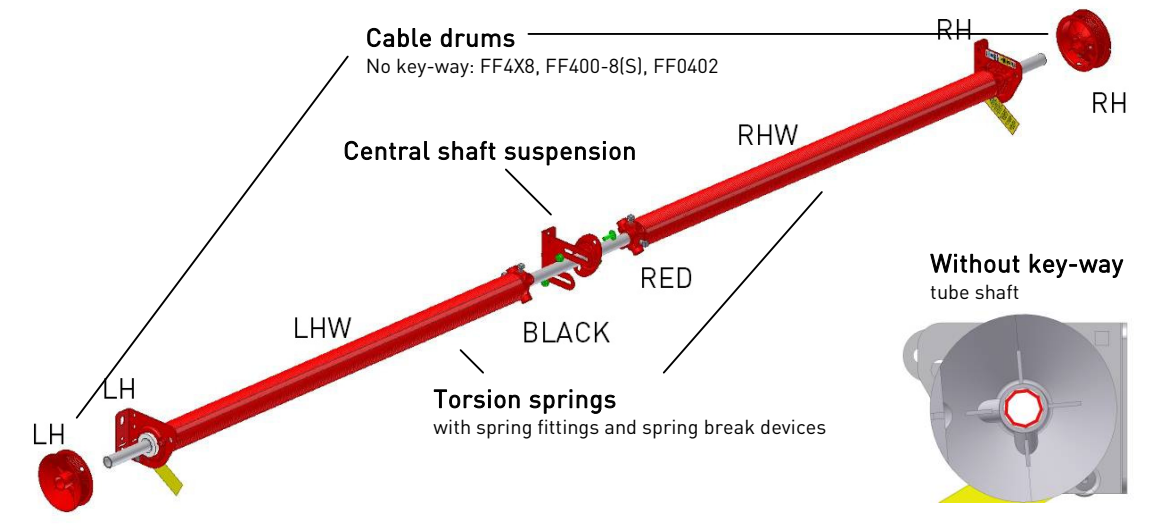

CENTRAL SHAFT SUSPENSION (2 ALTERNATIVES)

USA-MINI

312R

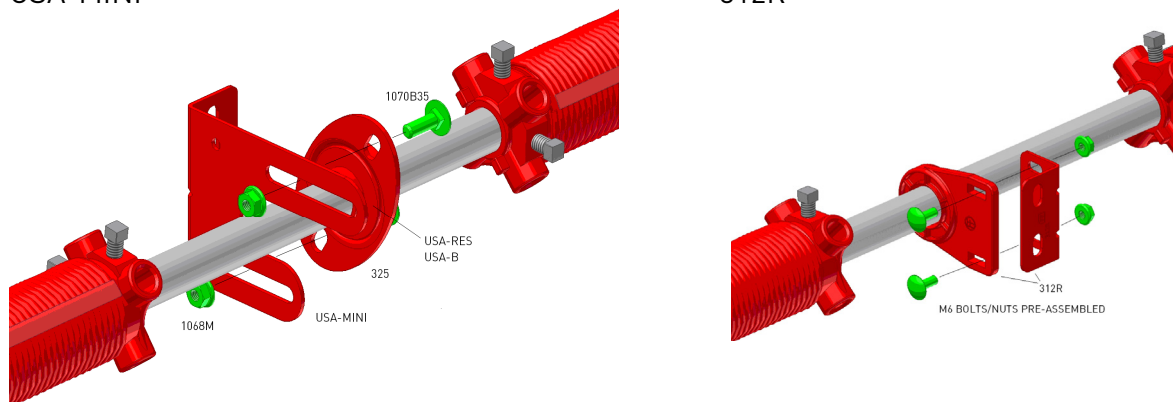

FF manual GB

rev.0 Feb-09

SHAFT SYSTEM INSTALLATION

DOOR W>3000mm (double doors)

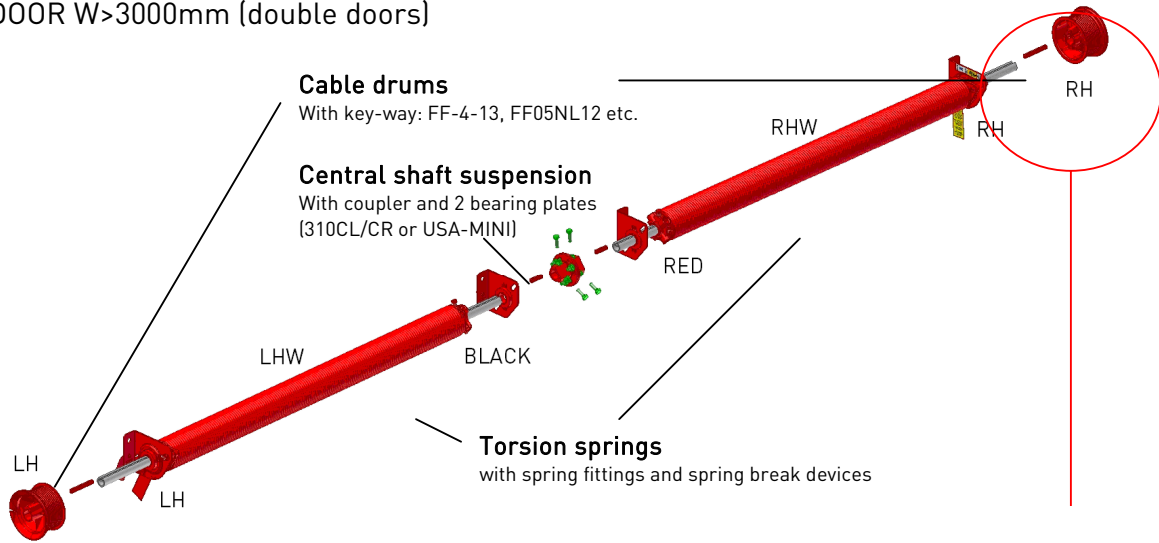

With key-way
tube key-wayed shaft

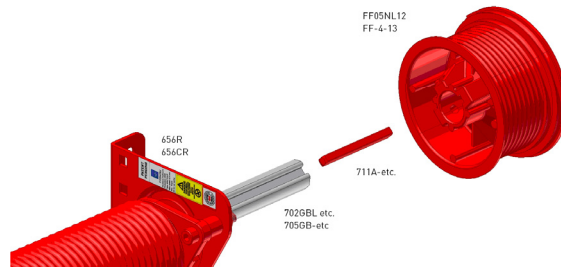

CENTRAL SHAFT SUSPENSION (W>3000mm)

Traditional installation

SuperClick® installation

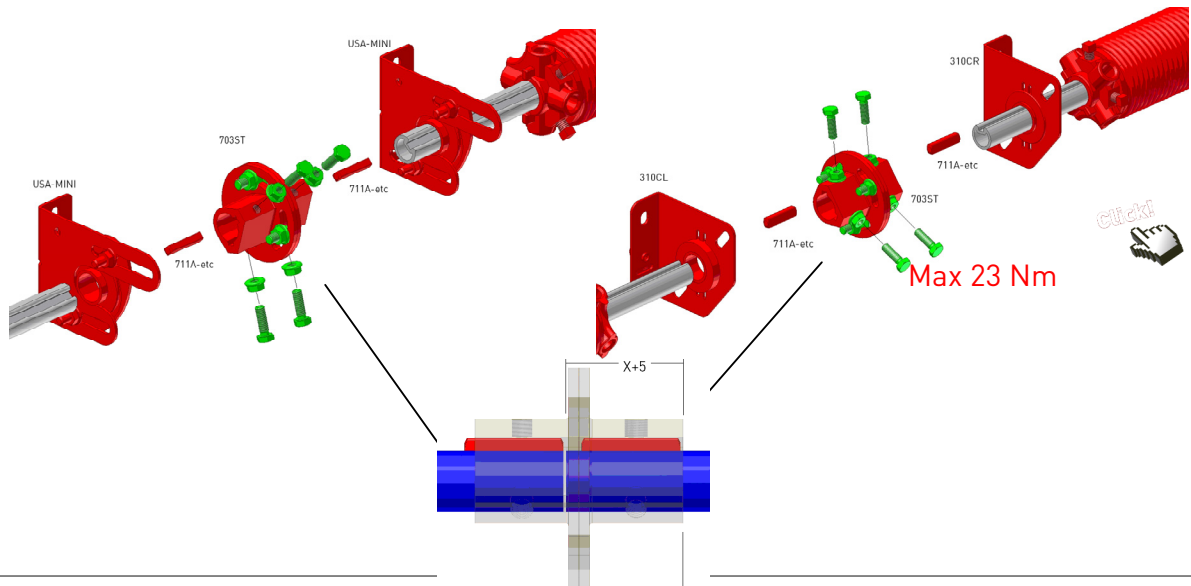

FF manual GB

rev.0 Feb-09

FIXATION TO TRACKS

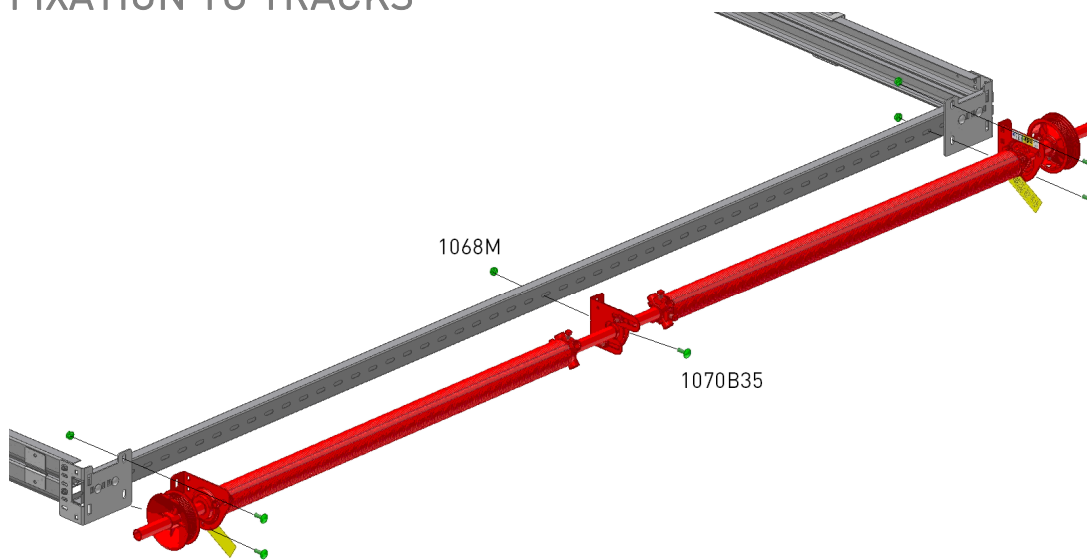

Traditional installation

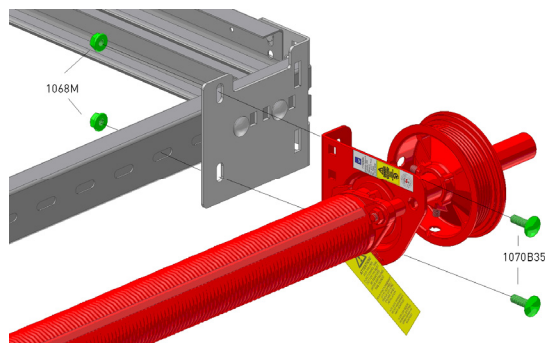

SuperClick® installation

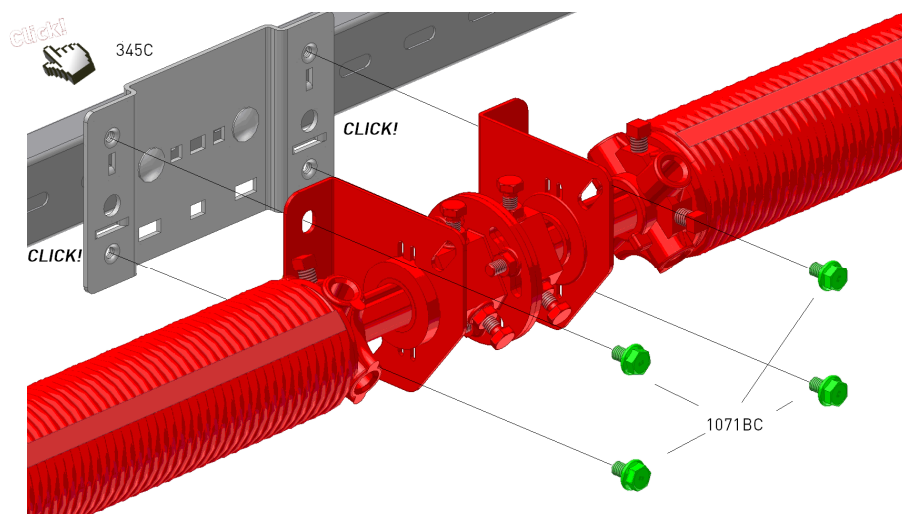
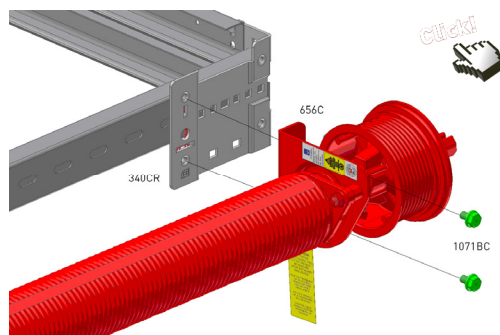

FF manual GB

rev.0 Feb-09

PANEL <> HARDWARE INSTALLATION

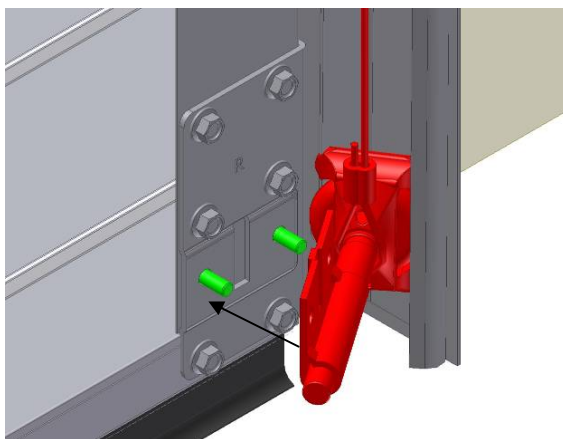
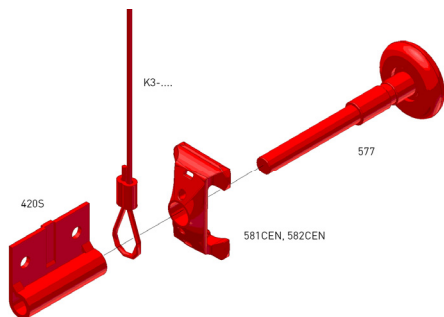
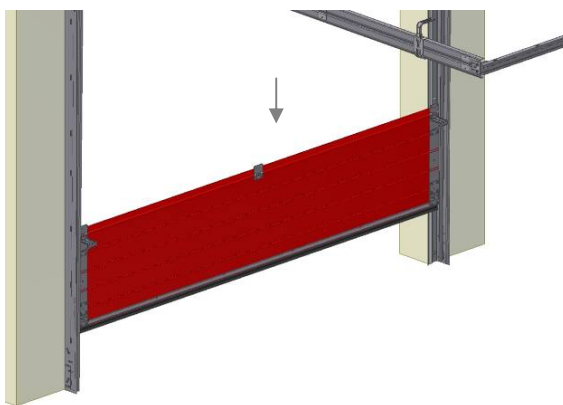
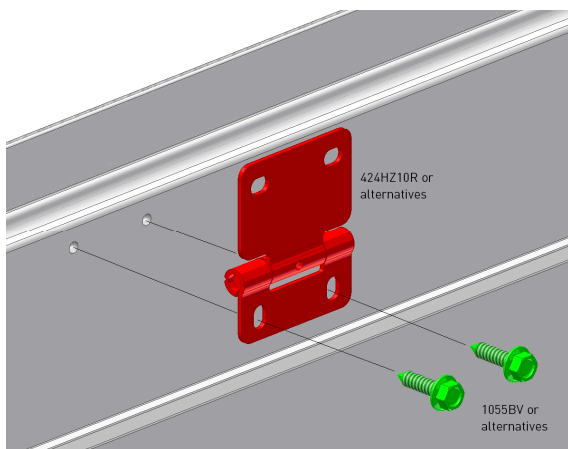
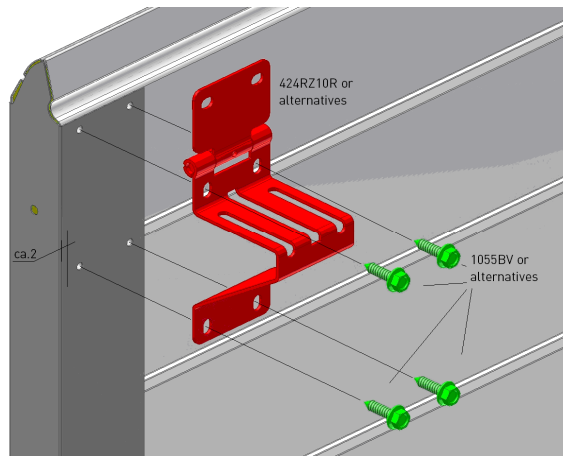
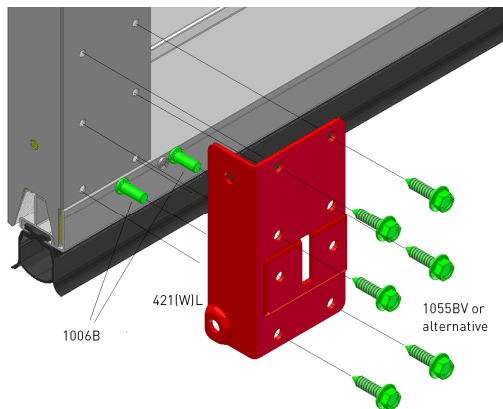

FF manual GB

rev.0 Feb-09

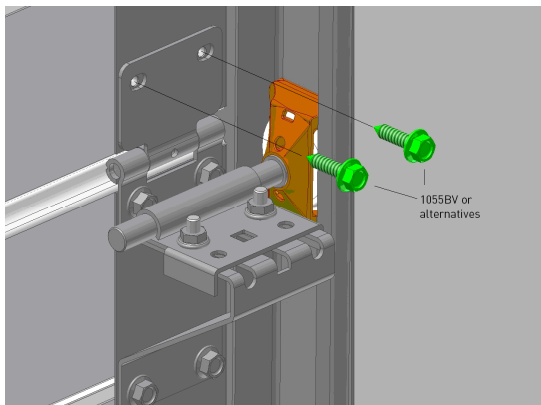
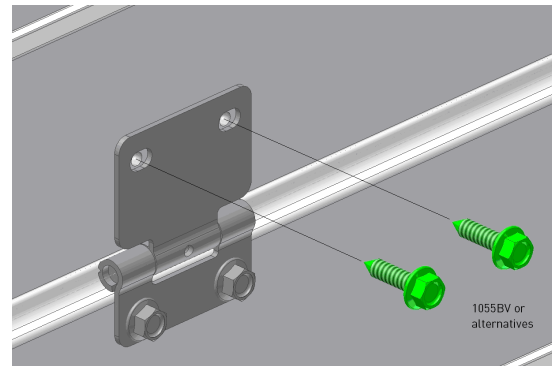
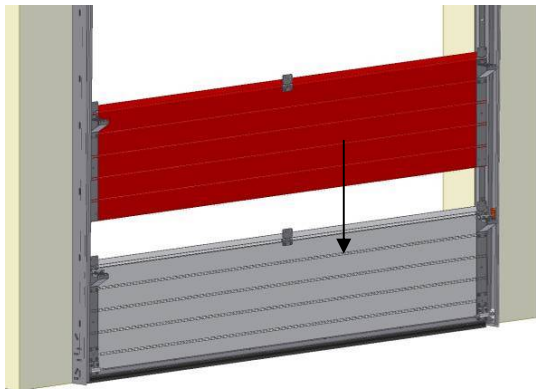
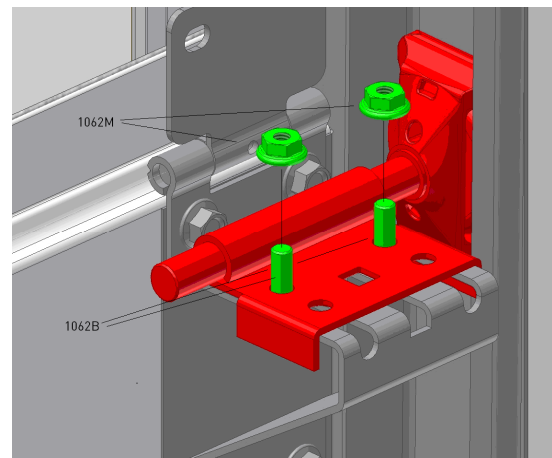
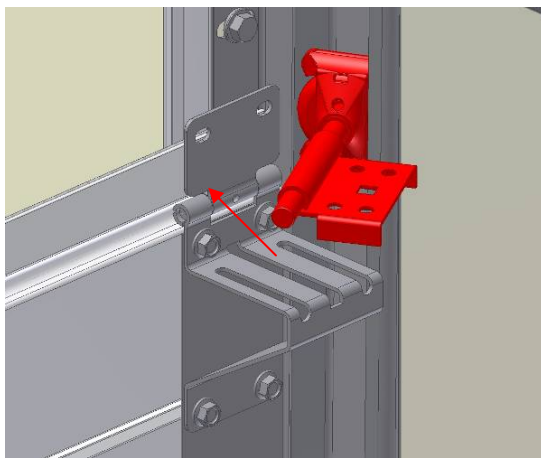
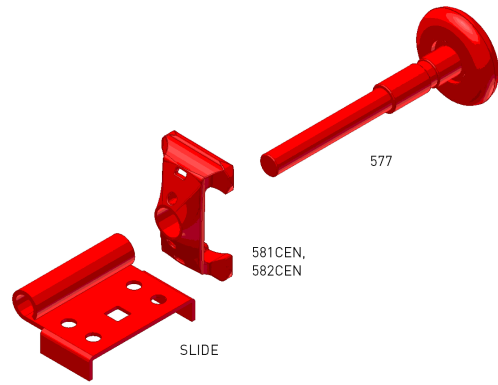
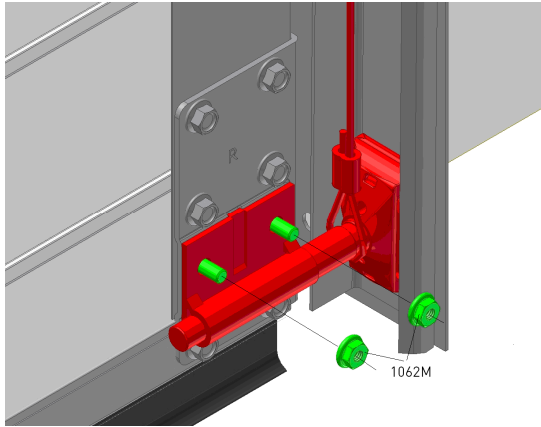

Alternative hinges: 411-series

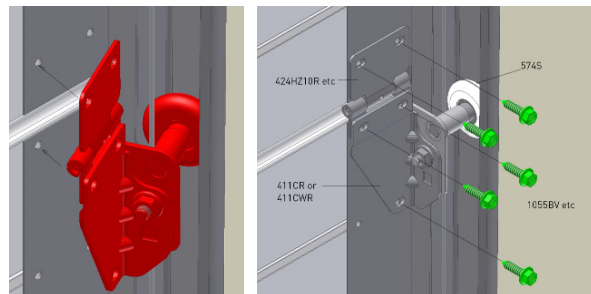

INSTALLATION TOP PANEL / TOP ROLLER CARRIER

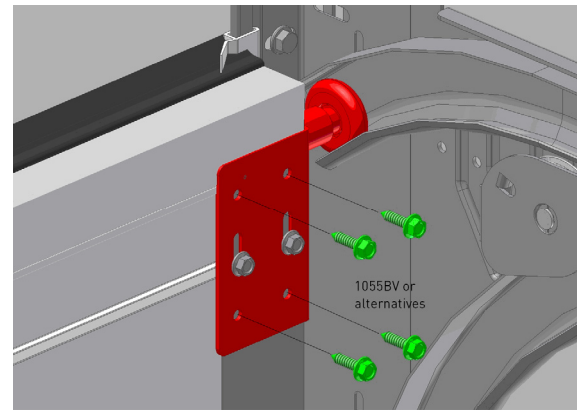
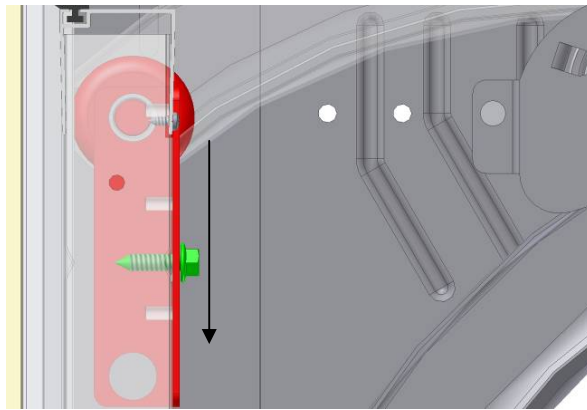
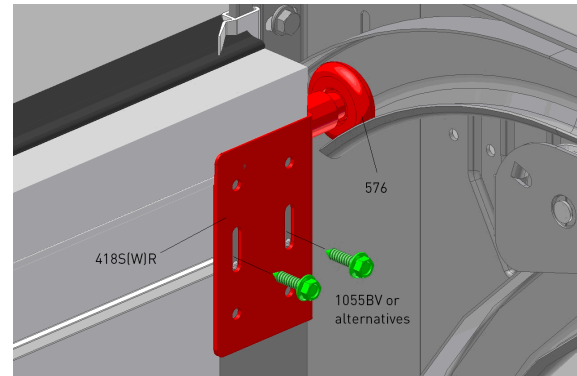
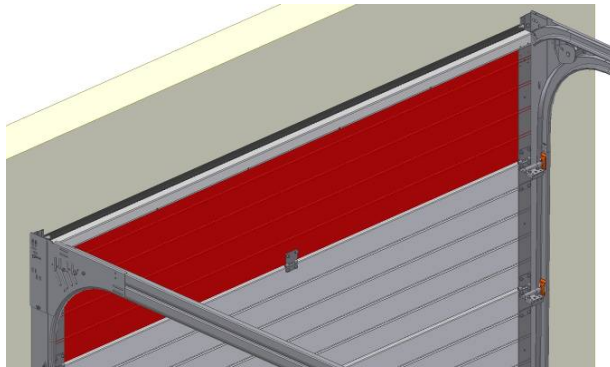

Close the door and secure the door panel. Loosen the two self-tapping screws (1055BV) securing the top roller holder (418SL/R) so that it can be displaced with a slight tick. Press the top panel against the side (upper) seal and slide the top roller holder as far as possible downwards and fix all screws. (minimum play between door panel and seal). The bearing roller lies snugly in the rounding of the bearing tracks.

Alternative top roller carrier: adjustable 419S-series

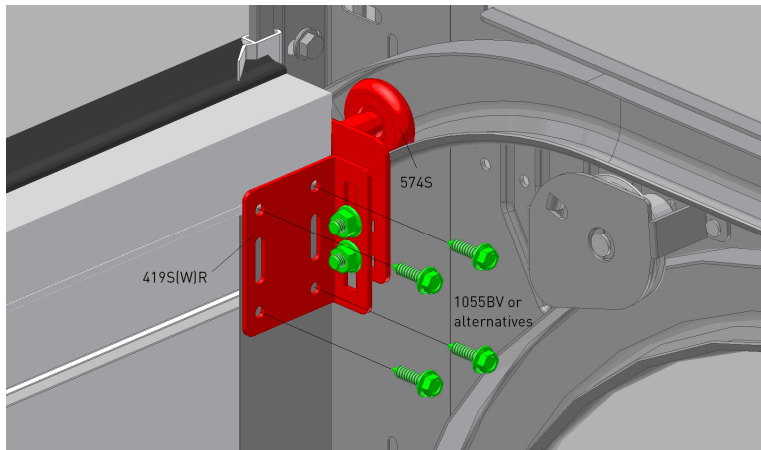

FF manual GB

rev.0 Feb-09

CABLES & TORSION SPRINGS

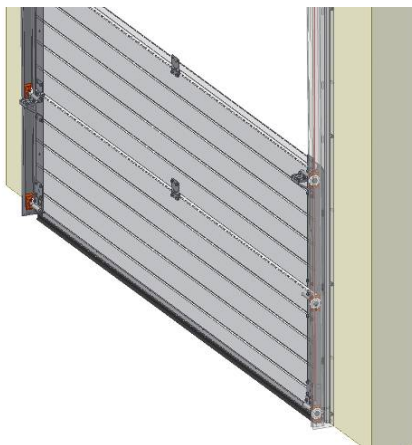
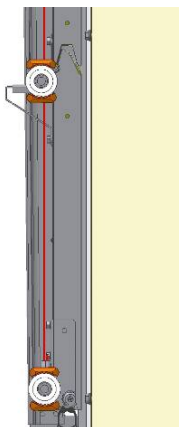

! Cable running behind the rollers to the cable drums

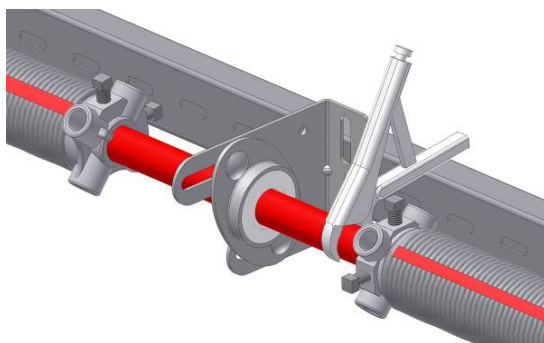

Without key-way: Fix shaft with clamp.

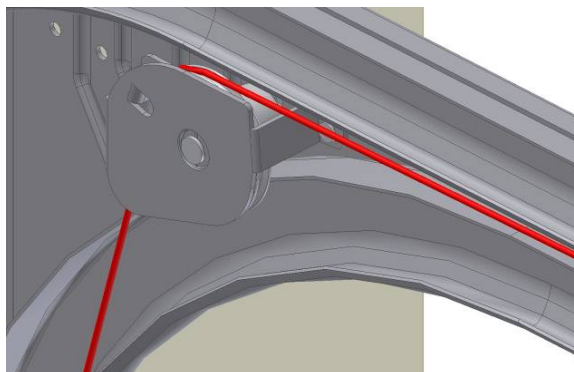

Bring cable trough pulley system to rear.

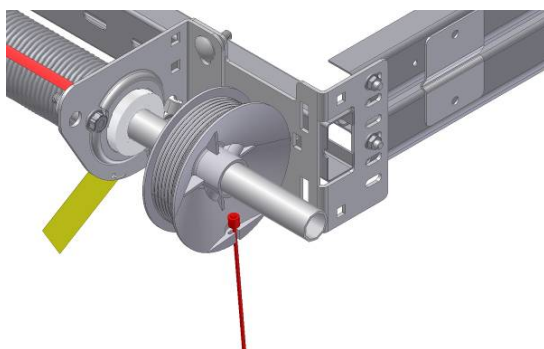

Hook in the cable end in the drum.

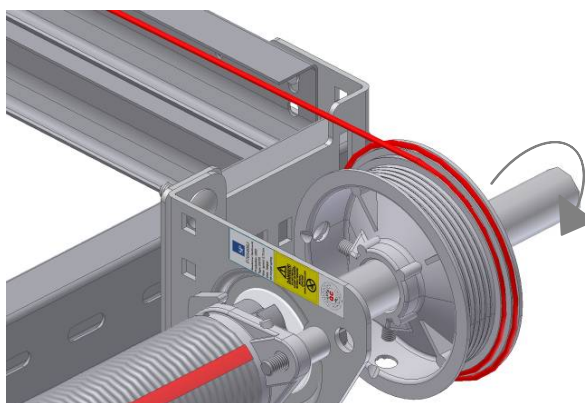

Rotate the drum for winding the cable.

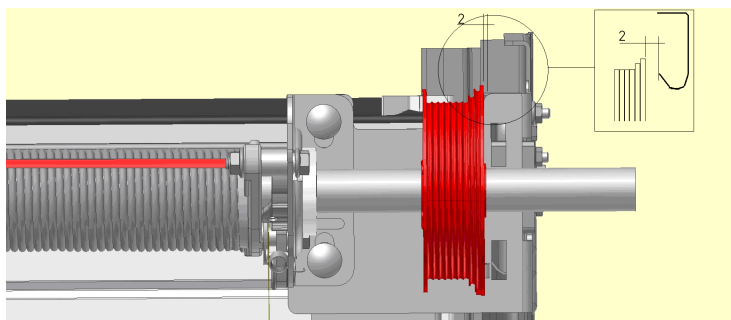

Position the drum on the shaft.

FF manual GB

rev.0 Feb-09

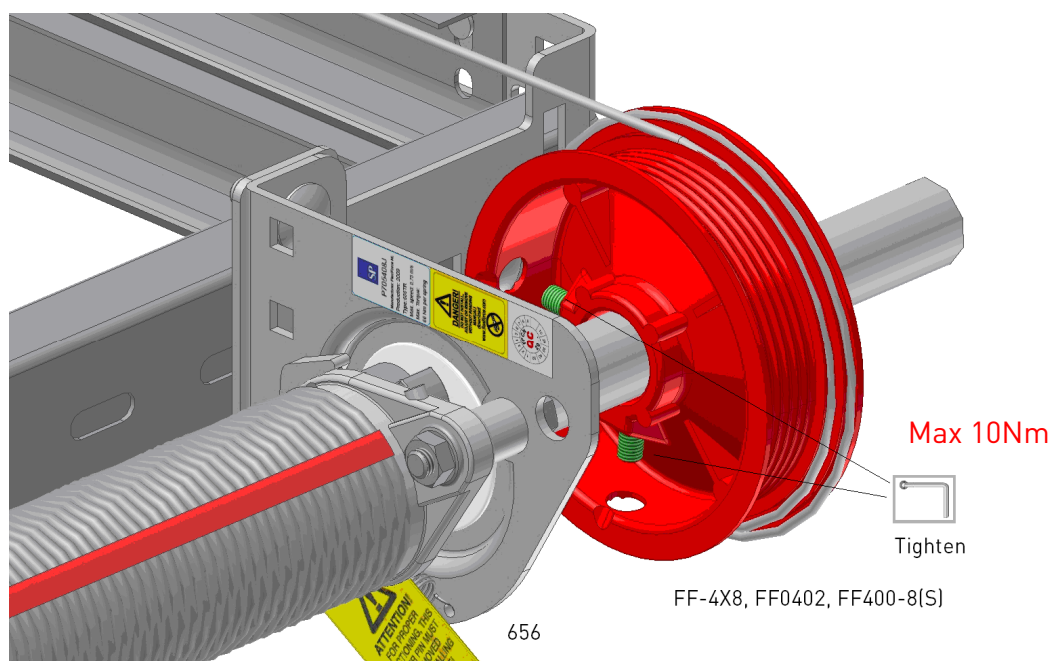

With key-way:

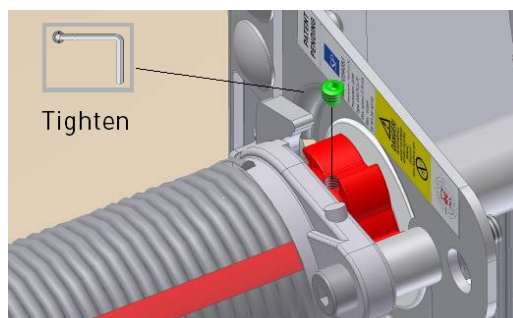
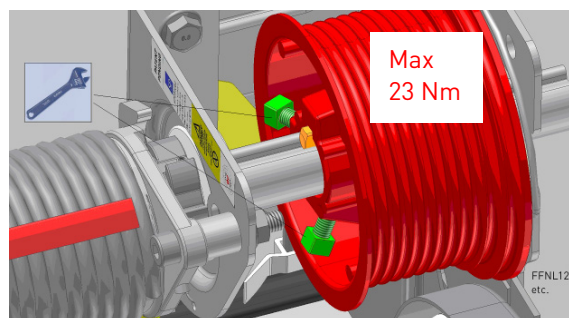

NB! See separate manual spring break device installation: 656Manual GB.pdf

FF manual GB

rev.0 Feb-09

TORSION SPRING TENSIONING



CAUTION!

Torsion springs are subject to considerable tension! Proceed at all times with extreme caution. Installation, maintenance and repair should be carried out only by experienced and properly trained overhead door fitters. Use correctly fitting and properly maintained tension levers (FlexiForce code RES-TB).

Number of turns on the torsion springs:

Height (H)	4 panels	5 panels
2000mm	7.1 turns	6.8 turns
2125mm	7.6 turns	7.3 turns
2250mm	8.0 turns	7.7 turns
2375mm	8.4 turns	8.7 turns
2500mm	8.5 turns	9.2 turns
	5 panels	6 panels
2750mm	9,4 turns	9,2 turns
3000mm	10,3 turns	10,0 turns

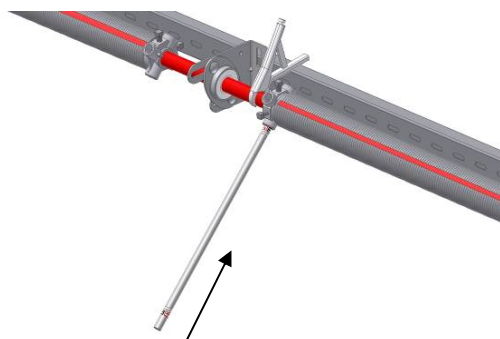
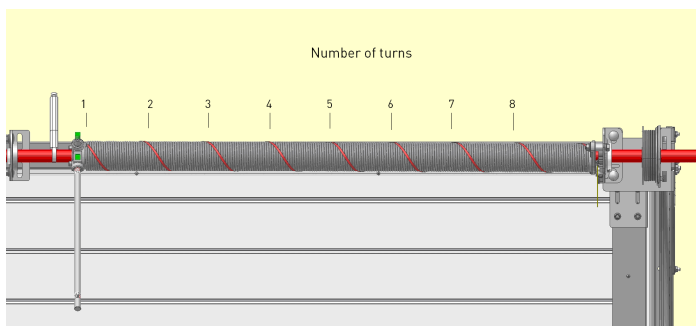

Insert the 1st tension lever completely into the slot.

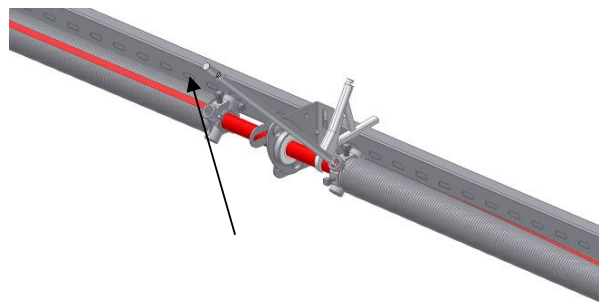

Turn the 1st tension lever a quarter turn such that the spring is tensioned.

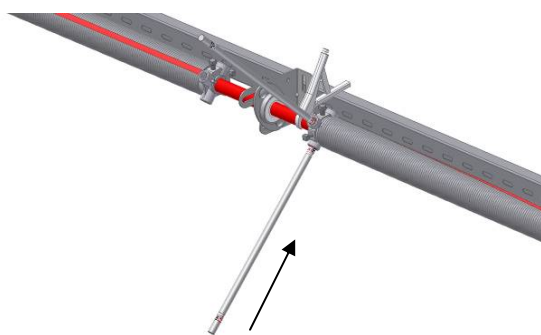

Insert the 2nd lever completely into the next slot. Take over the tension of the spring from the 1st tension lever to the 2nd tension lever. Remove the 1st tension lever from the slot. Turn the 1st tension lever a quarter turn such the spring is tensioned. Repeat until number of turns is achieved. Then fix the spring plug to the shaft. Check the door balance and adjust the springs if necessary (equally both springs!)

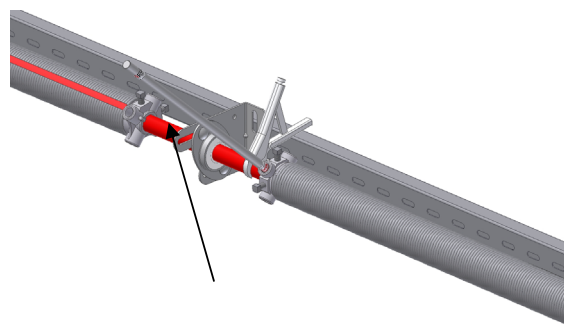

FF manual GB

rev.0 Feb-09

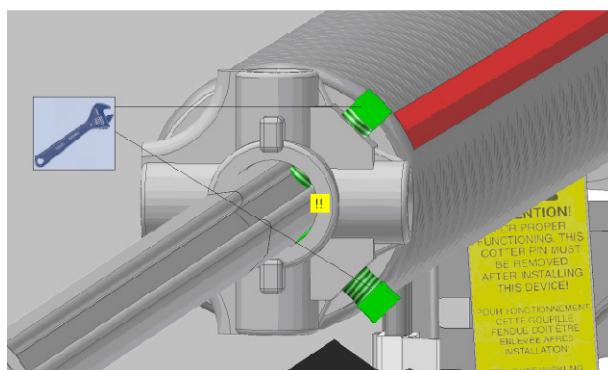
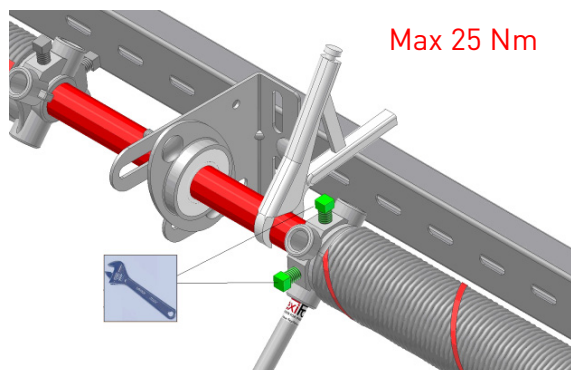

FINISHING THE DOOR

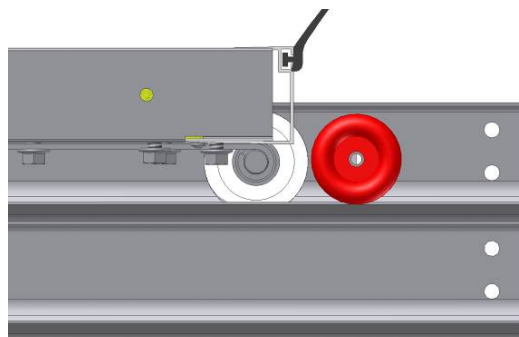
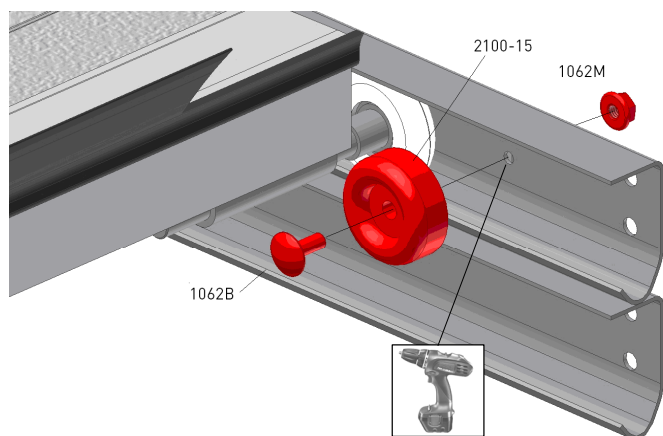

GREASING DOOR PARTS

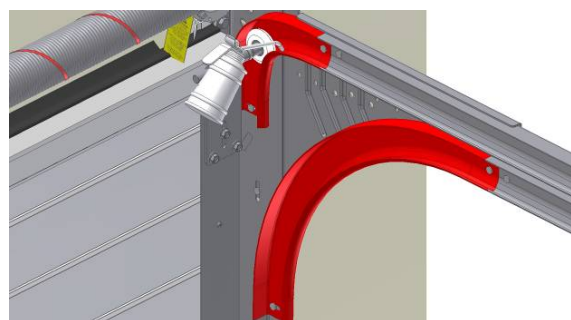
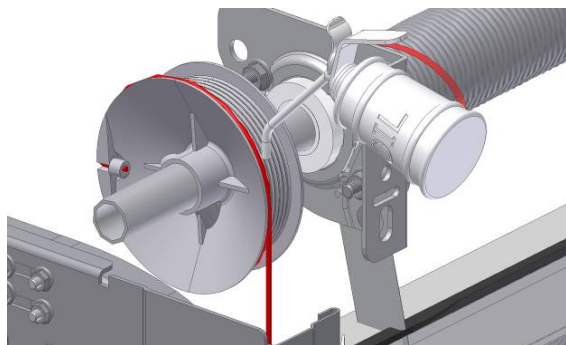
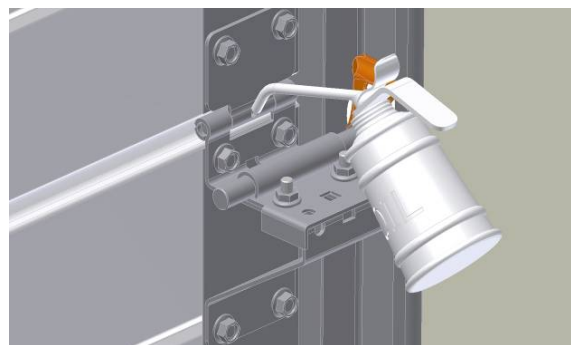

FF manual GB

rev.0 Feb-09

RE-ADJUSTING THE DOOR

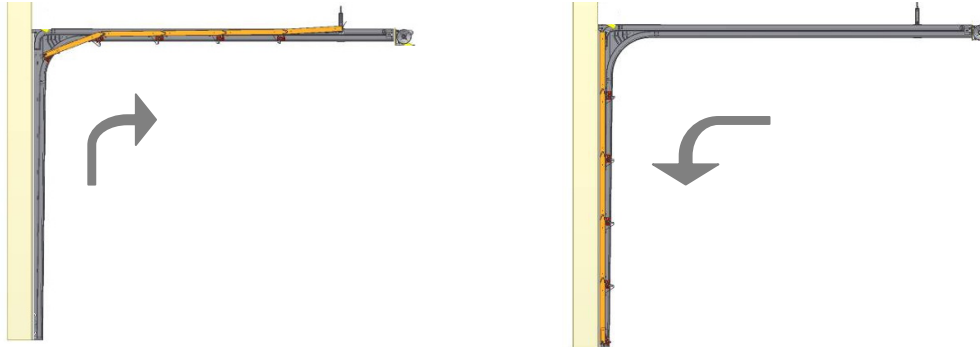

Open and close the door for checking all the settings.

When the door panel is not hanging completely horizontally in the lifting cables in (almost) closed conditions there are several options for fine adjustment.

- A. Loosen the securing bolts of the cable drum and the drum relative to the tube shaft.
- B. When a coupling is employed this may be adjusted to ensure a better horizontal setting.

Horizontal movement of the door can be limited (to max. 5mm) by installing 2065 distance rings on the roller shafts.

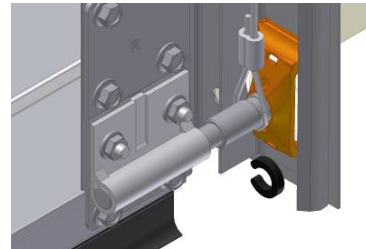

SAFETY LABELS ON THE DOOR



LABEL-GB etc.

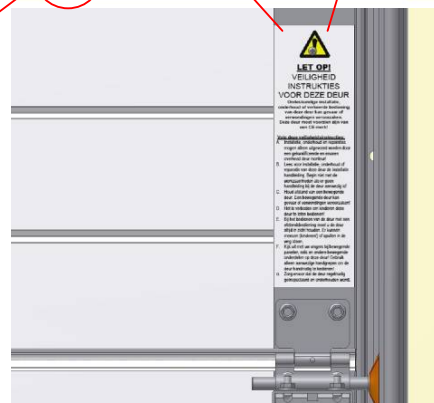
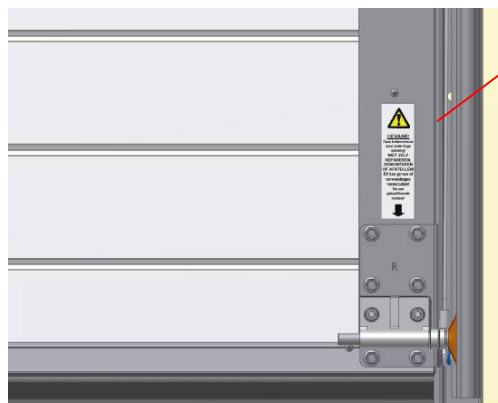
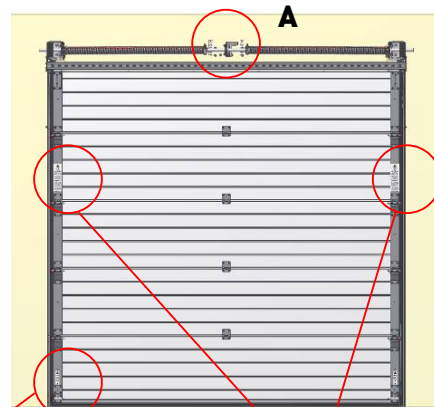

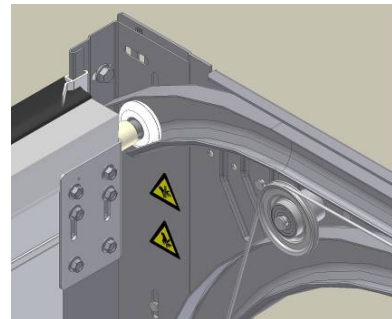
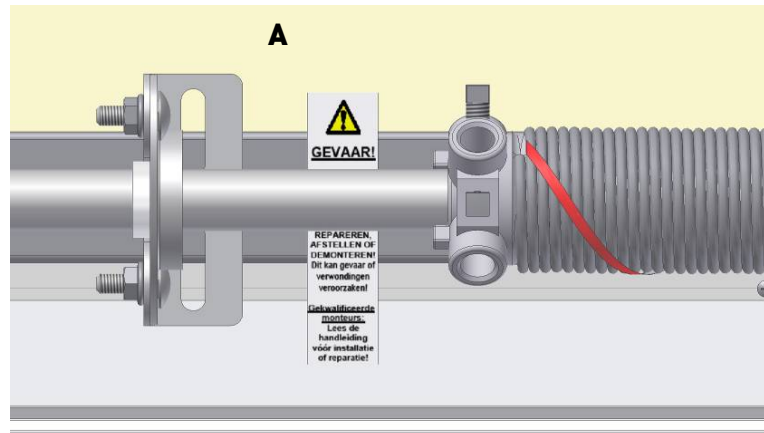

FF manual GB

rev.0 Feb-09



Install any additional accessories that you have ordered separately such as: Handgrip, lock, etc. See separate instructions in product packaging.

-  **NB!** A lock may not be fitted to an electrically driven door.
-  **NB!** A manually operated door should always be equipped with a hand grip, installed at a safe location on the door.
-  **NB!** Do NOT INSTALL a pull rope with a power operated door at any time!! This can cause serious injuries or danger to the user of the door!

Place your CE identification plate on the door (mandated!!) together with any warning labels required.

Hand over necessary documents to the end-user:

- User manual
- Dismantling instructions (included in this manual)
- Maintenance instructions (included in the user manual)
- Service log book
- Declaration of conformity IIa declaring the door is according to EN-13241-1.

FF manual GB

rev.0 Feb-09

Visit www.flexiforce.com for the most recent update of information on your obligations towards handing over a safe-to-use door.

OPTIONAL: E-OPERATION

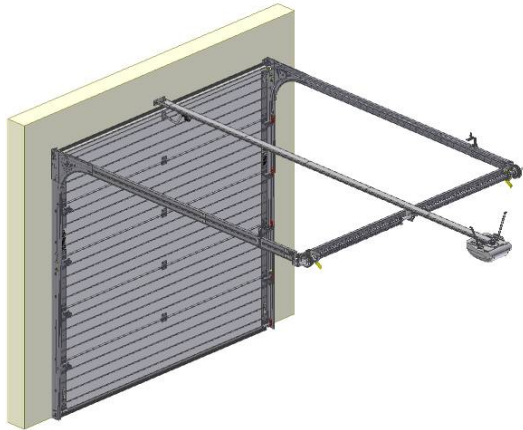

When you have selected an electrical operator drive (LIFTMASTER LM60K/R or other), then this should be assembled in conformity with the handbook supplied with this operator and above displayed instructions. You should clearly follow the instructions for electrical operation in this handbook.

In order to maintain the closing peak force of the door within the CE-standards the attachment point of the drawbar should be fixed at the proper position. Ask your supplier for the correct position!



NB! The person installing the door must check thoroughly if the combination between this door and the selected operator is safe to use (ITTR-approval report). Keep in mind the max. peak force that is allowed when closing the door. People could get hurt if the adjustment of the operator software, or the installation of the operator or the selected operator on this door, are not checked correctly!!

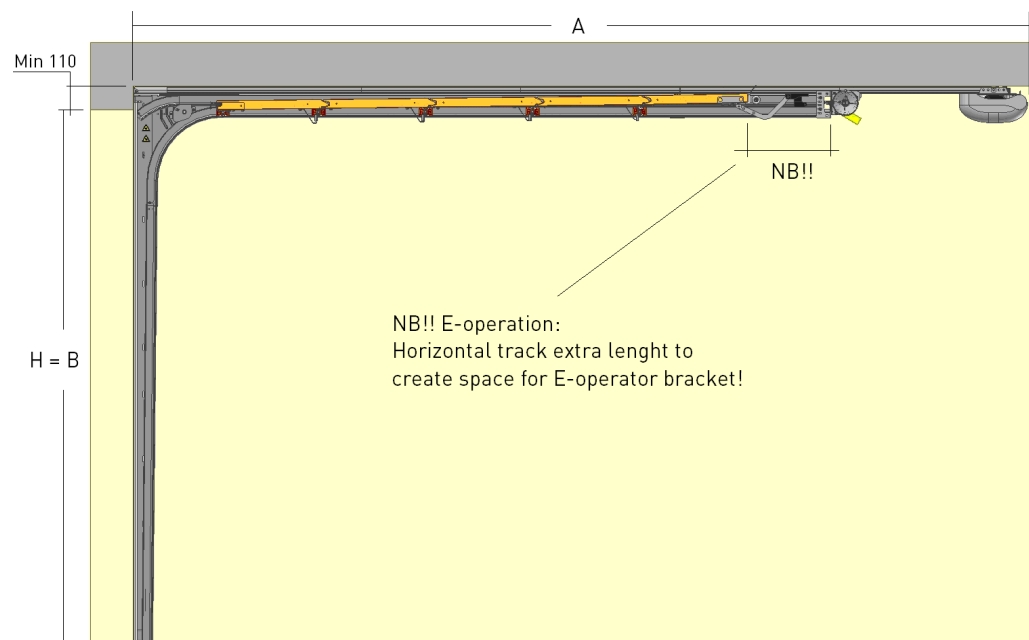

FF manual GB

rev.0 Feb-09

So combinations:

- RSV10 + RS70H30
- RSV20 + RS70H40
- RSV30 + RS70H50
- RSV40 + RS70H60
- RSV50 + RS70H60
- RSV60 + RS70H70

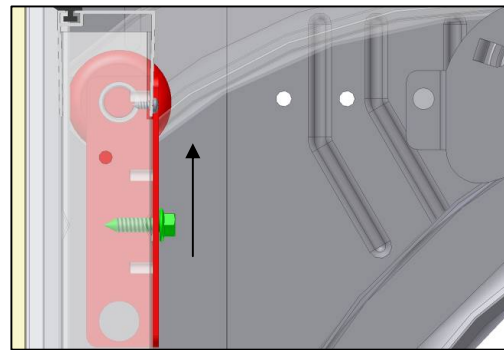

FF manual GB

rev.0 Feb-09

OPTIONAL: TANDEM ROLLERS

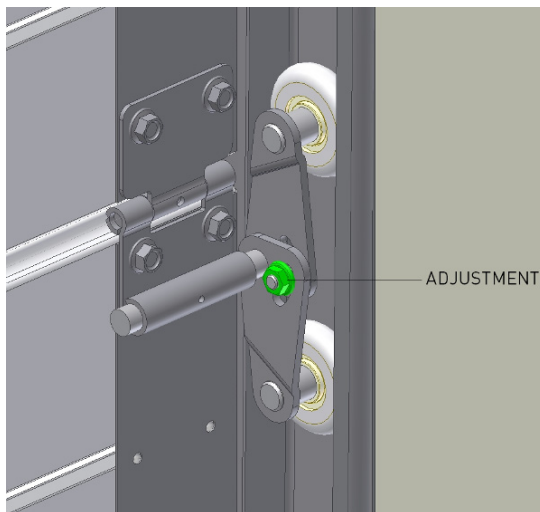
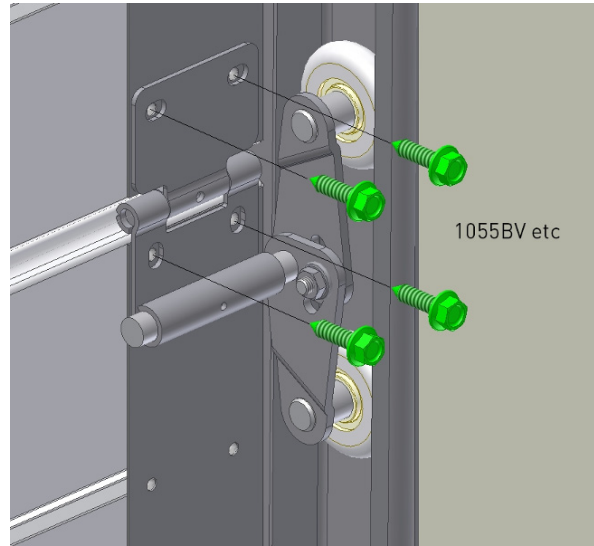
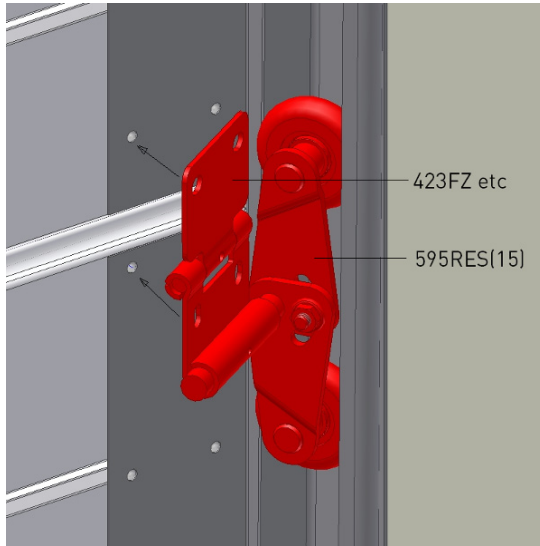

FF manual GB

rev.0 Feb-09

PANEL ASSEMBLY

INSTALLING END CAPS

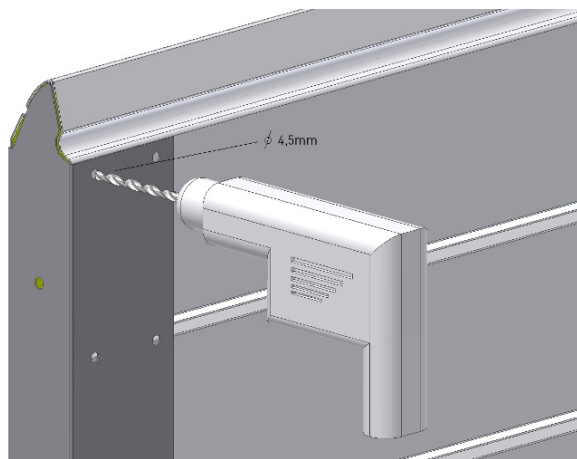

40ES500L etc
or
alternatives

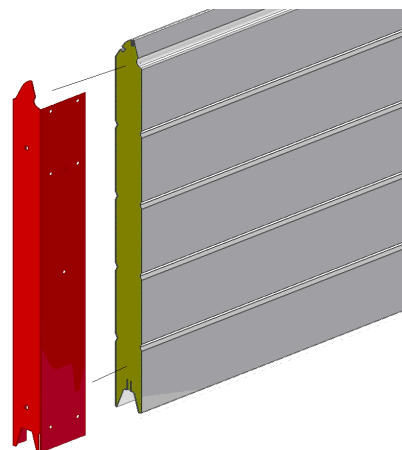

POSITIONING OF END CAPS PER PANEL BRAND

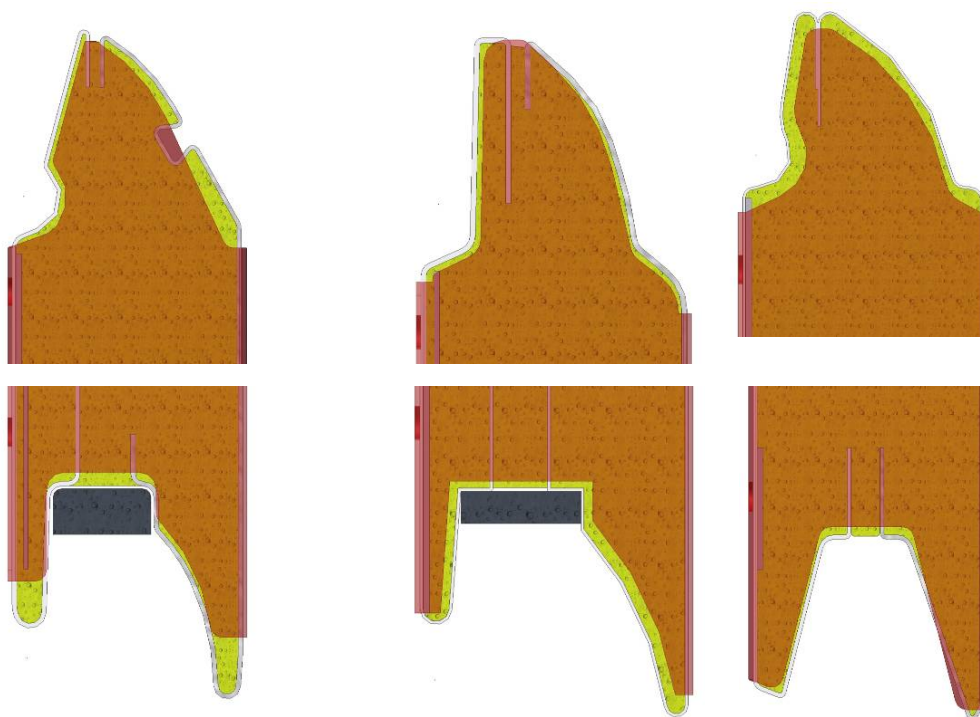

Kingspan panel

40ES500L/R, 40ES610L/R
40ES500WL/R, 40ES610WL/R (RAL9010)
40EM500L/R, 40EM610L/R
40EM500WL/R, 40EM610WL/R (RAL9010)

Tecsedo panel

40TS500L/R, 40TS610L/R
40TS500WL/R, 40TS610WL/R
40TM500L/R, 40TM610L/R
40TM500WL/R, 40TM610WL/R

Metecno panel

40FS500L/R, 40FS610L/R
40FS500WL/R, 40FS610WL/R
40FM500L/R, 40FM610L/R
40FM500WL/R, 40FM610WL/R

= W + 21mm



FF manual GB

rev.0 Feb-09

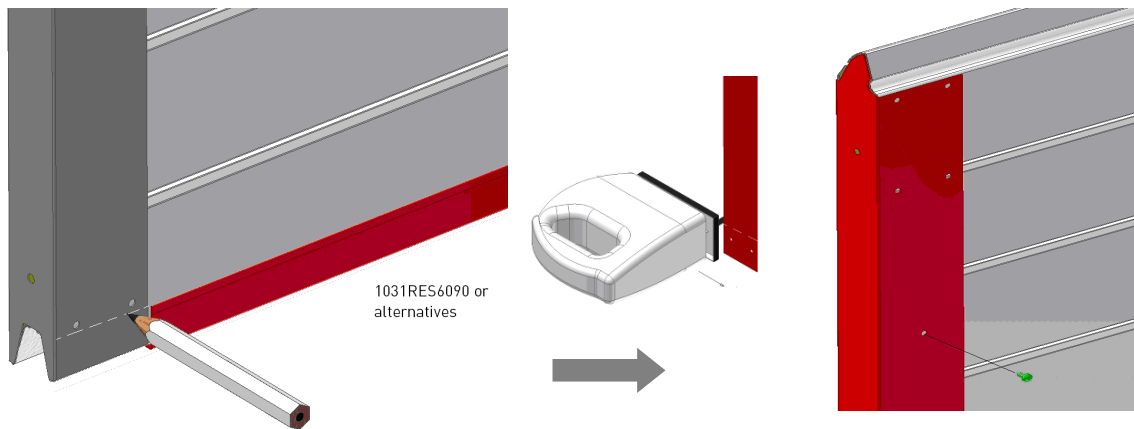

INSTALLING BOTTOM ALU + SEAL

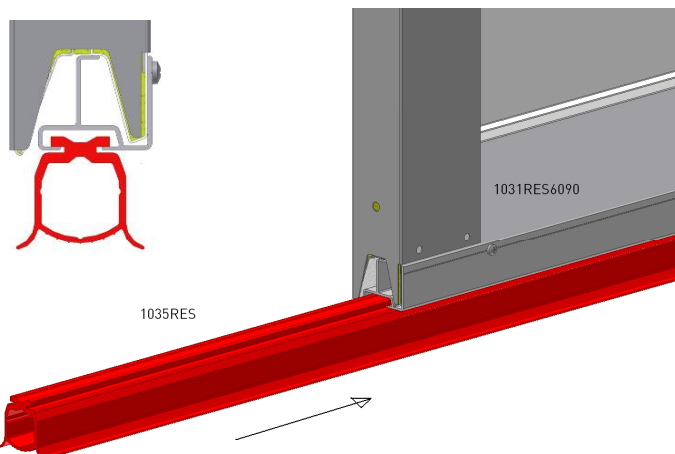
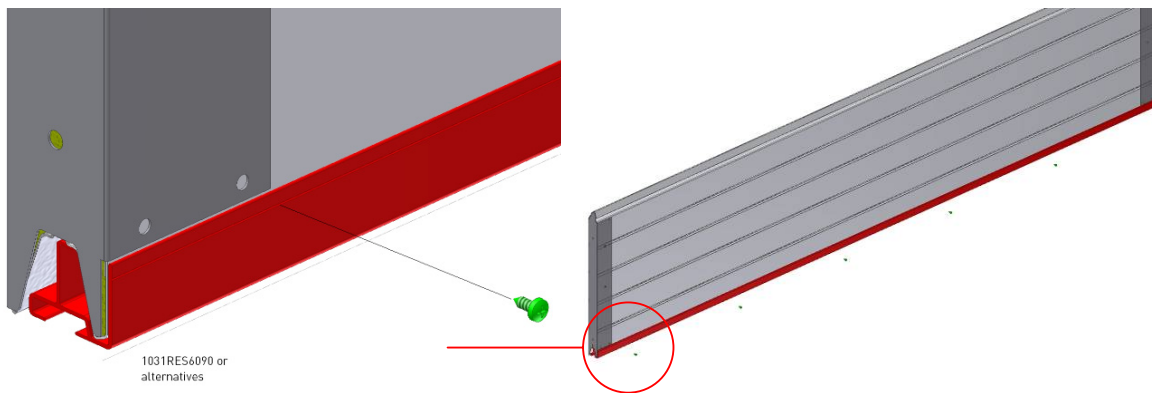

FF manual GB

rev.0 Feb-09

CUTTING / FINISHING TOP PANEL

⚠ NB! Make sure that the bottom panel will not be cut for adjusting the panel or door height. This should be done with the top section only! The attachment of the bottom bracket, which is holding the complete door weight, is relying on the construction of the panel. Danger can occur if the panel is cut at this point.

Total door panel height = Days Opening Height (H) + 15mm

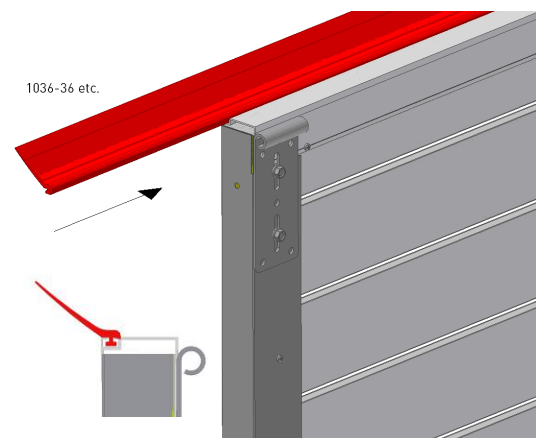
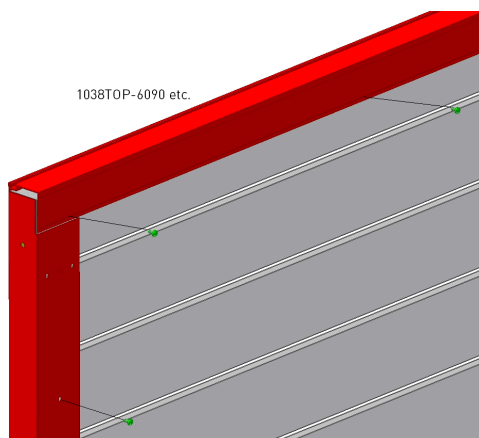
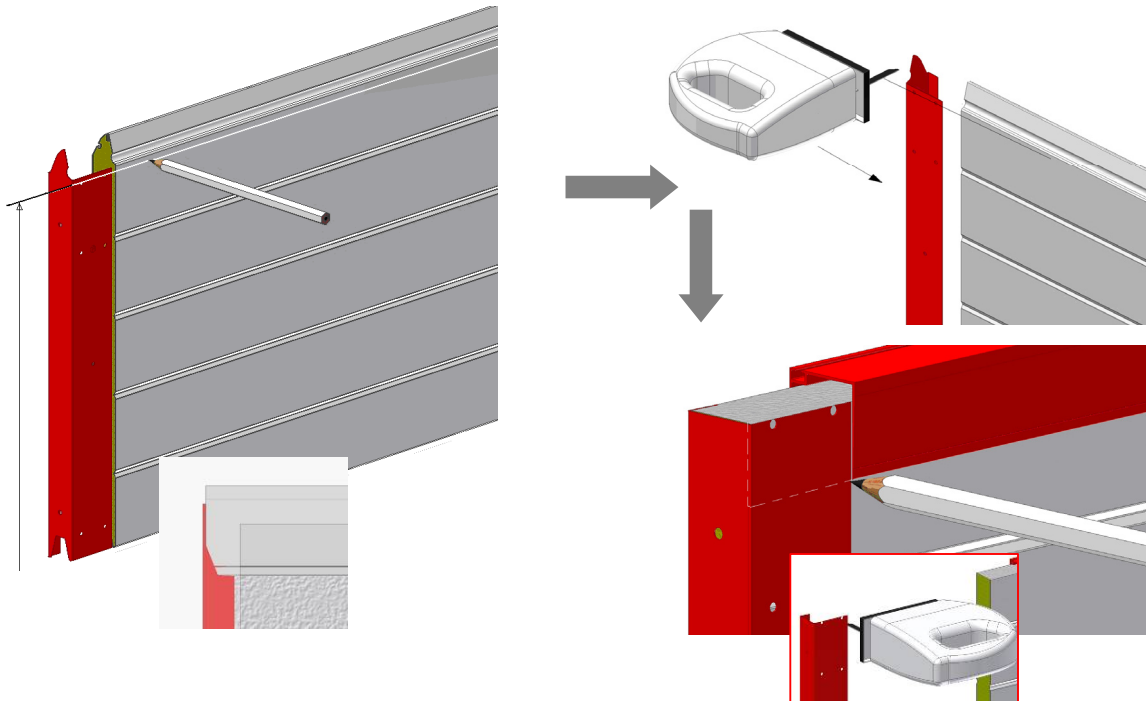

TROUBLESHOOTING

What should be checked if the door is not balanced properly?

When a door is not well in balance, then it is necessary to check first the following details :

1. **Is the given information correct :**
 - weight of the door leaf (including hardware)
 - is the division of the weight equal on each panel, or are there panels with a different weight than the others, for instance by the application of different panels (glass, pass door with heavy profiles).
2. **Are the correct parts supplied and fitted?**
especially the drums and springs are important :
 - are the correct dimensions supplied ?
3. **Is the door properly installed?**
 - horizontal tracks really horizontally and not with inclination.
4. **Were modifications made afterwards ?**
 - check if any changes were made during the fitting, or if a pass door was fitted later, or any reinforcement profiles fitted etc.
5. **Is the e-operator installed and selected properly?**
 - Is the installed e-operator suitable for this door?
 - Is the e-operator power adjusted properly for this door? (See installation manual operator)
 - Is the connection of the drawbar to the top-panel on the right position? (See attachment and manual operator).

WHAT TO DO AFTER CABLE BREAK OR SPRING BREAK?



NB! Also make sure to instruct the user about this.

After spring breaking the door will be stopped by the 656-series spring break devices. The end user must contact immediately a qualified overhead door mechanic. The spring breaking device is a so called "one-shot" device. After it has acted, it must be replaced, together with all other possibly damaged components of the door, such as torsion springs, spring plugs, bearing plates etc. The door has to be inspected thoroughly. See separate manual 656 spring break device. After cable breaking, the door will be stopped by the second cable, which is designed to be strong enough to hold the weight of the door. Again, qualified overhead door mechanics must inspect the door and replace all possibly damaged components, such as: bottom brackets, cable, roller carriers, rollers, etc.

SPRING IDENTIFICATION

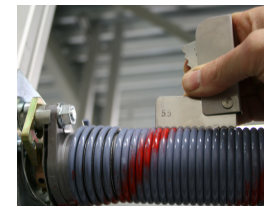
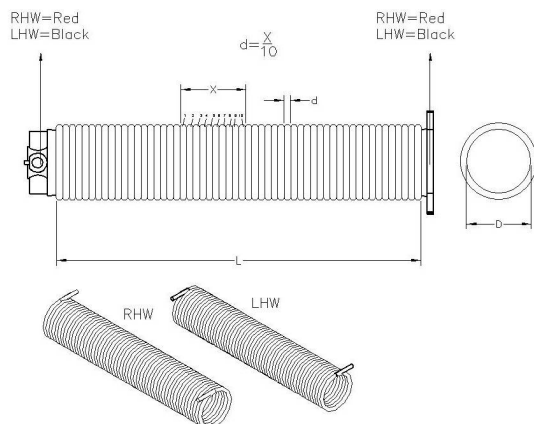

FlexiForce® spring gauge: WGD10

DISMANTLING THE OVERHEAD DOOR



ATTENTION! WARNING!

To dismantle an existing overhead door, a number of precautions must be taken. For the safety of all concerned pay heed to the warnings and instructions given below! If in doubt, contact your supplier.

Dismantling should only be carried out by experienced fitters. This manual is not suitable for d.i.y. purposes or for use by trainee fitters.

This manual only describes the installation/dismantling of hardware for overhead doors and as such must be supplemented with instructions for any additional components.

FOR ANY DETAILS ON THESE DISMANTLING INSTRUCTIONS, WE REFER TO THE INSTALLATION CHAPTERS OF THIS MANUAL WHERE DRAWINGS AND DETAILS ARE DISPLAYED.

STEP 1. De-tensioning the torsion spring(s)



CAUTION ! Torsion springs and bottom brackets are under high tension. Exercise at all times great caution. Use properly fitting and maintained tension irons (see drawing).

Start dismantling of the door by closing the door and securing its movement with a clamp on the vertical track. First the tension on the torsions springs and cable has to be released. Do this by following these instructions :

- 1 Insert the 1st tensioning iron fully into the tensioning aperture.
- 2 Take over the tension of the spring with this tensioning iron.
- 3 Loosen the bolts in the tensioning plug and remove the key.
- 4 Turn the 1st tensioning iron in the direction required.
- 5 Insert the 2nd tensioning iron fully into the next tensioning aperture.
- 6 Take over the tensioning of the spring from the 1st tensioning iron with the 2nd tensioning iron.
- 7 Remove the 1st tensioning iron from the aperture.
- 8 Turn the 2nd tensioning iron a quarter turn in the direction required.
- 9 Insert the 1st tensioning iron fully into the tensioning aperture.
- 10 Take over the tensioning of the spring from the 2nd tensioning iron with the 1st tensioning iron.
- 11 Repeat steps 4 through 10 until all tension is released.
- 12 Remove the last tensioning iron.

STEP 2. Disconnect the electrical operator. Follow any instructions given in the separate manual of the operator.

STEP 3. Loosen the cable drums and remove the keys. Act carefully, there might be some tension left on the cable. Check if the cable is slack. Remove the cable by disconnecting it from the bottom bracket and cable drum.

STEP 4. Dismantle the horizontal track construction.

STEP 5. Remove the panels one by one from the vertical track construction, starting with the top panel. Do this by loosening the hinges and rollers first.

STEP 6. Remove the shaft construction from the lintel, after you have dismantled the E-operator from the shaft. If the shaft is divided and connected with a coupler, first disconnect the coupler and carefully remove both halves of the shaft system.



Attention ! Watch out for parts that might slide of the shaft, such as cable drums, bearings or keys.

STEP 7. Remove vertical tracks and angles from the building construction.



STEP 8. Make sure that you remove all the parts and panels in an environment kindly way. Check with your local authorities where and how you can leave this as garbage.

MAINTENANCE AND REPLACEMENT OF PARTS RESIDENTIAL DOORS

An overhead door should be maintained and checked regularly to ensure safe operation and use. This is described in the EN-norms.

GENERAL:

- 1 Torsion springs, brackets and other components which are attached to the springs and cables, are under extreme tension. If not handled properly, injuries or damages might occur!
So, working on these components may only be carried out by qualified overhead door mechanics!
- 2 Replacement of broken or worn components should always be done by qualified overhead door mechanics.
- 3 When checking the door, always disconnect the electrical main power supply. Make sure that it is blocked against re-engaging without you knowing it.

REGULAR MAINTENANCE:

After installation:

- | | |
|--|----------|
| 1. Grease running part of the tracks | MECHANIC |
| 2. Grease the bearings of the rollers | MECHANIC |
| 3. Grease the shafts of the rollers | MECHANIC |
| 4. Grease the bearings of the shaft | MECHANIC |
| 5. Grease the hinge pins | MECHANIC |
| 6. Grease the lock | MECHANIC |
| 7. Protect the panels with carwax | USER |
| 8. Grease the rubbers slightly with vasaline | USER |

After 3 months:

- | | |
|--|----------|
| 1. Complete inspection visually | MECHANIC |
| 2. Check balancing system and adjust if needed | MECHANIC |
| 3. Grease all the above mentioned points if needed | MECHANIC |

Every 6 months (or after every 750 cycles):

- | | |
|--|------|
| 1. Check side seals on damage or wear and tear | USER |
| 2. Check top seal on damage or wear and tear | USER |
| 3. Check bottom seal on damage or wear and tear | USER |
| 4. Grease all above mentioned points | USER |
| 5. Clean the panels | USER |
| 6. Clean the windows (only water wash, do not use cloth) | USER |
| 7. Remove dirt and waste from the door or its surroundings | USER |

Every 12 months (or after every 1500 cycles):

- | | |
|--|----------|
| 1. Check or test the fixation of the springs to the fittings | MECHANIC |
| 2. Check the balance of the door and adjust if needed | MECHANIC |
| 3. Check the cables for damage or wear and tear | MECHANIC |
| 4. Check the cable connection points on drums and bottom bracket | MECHANIC |
| 5. Check the roller on wear and free moving space | MECHANIC |
| 6. Check the hinges on breaking | MECHANIC |

- | | |
|--|----------|
| 7. Check the panels on damage, wear and roust | MECHANIC |
| 8. Check the spring breaking device acc. to instructions in manual | MECHANIC |
| 9. Check and test the safety edge system with operator | MECHANIC |
| 10. Check the manual operation of the door | MECHANIC |
| 11. Grease the springs | MECHANIC |

After two years (or after every 3000 cycles):

- | | |
|--|----------|
| 1. Grease all the above mentioned points | MECHANIC |
| 2. Check or test the fixation of the springs to the fittings | MECHANIC |
| 2. Check the balance of the door and adjust if needed | MECHANIC |
| 3. Check the cables for damage or wear and tear | MECHANIC |
| 4. Check the cable connection points on drums and bottom bracket | MECHANIC |
| 5. Check the roller on wear and free moving space | MECHANIC |
| 6. Check the hinges on breaking | MECHANIC |
| 7. Check the panels on damage, wear and roust | MECHANIC |
| 8. Check the spring breaking device acc. to instructions in manual | MECHANIC |
| 9. Check and test the safety edge system with operator | MECHANIC |
| 10. Check the manual operation of the door | MECHANIC |
| 11. Grease the springs | MECHANIC |
| 12. Check side seals on damage or wear and tear | MECHANIC |
| 13. Check top seal on damage or wear and tear | MECHANIC |
| 14. Check bottom seal on damage or wear and tear | MECHANIC |
| 15. Check the shaft on wear and tear or damage | MECHANIC |
| 16. Check the bottom bracket on wear and tear and damage | MECHANIC |
| 17. Check the connection of the drum to the shaft (keys!) | MECHANIC |
| 18. Check and re-fix the bolt of the coupler | MECHANIC |
| 19. Check the connections of the track system | MECHANIC |
| 20. Check the suspension of the door to the lintel and ceiling | MECHANIC |

Use for greasing : PTFE or SAE20 or WD40

Use for cleaning : Soft soap with water. Do not use aggressive soap or cloth.